

Athalon™ maximum-life filters deliver the highest level of sustained fluid system protection, across all applications, regardless of severity.

Featuring an industry leading $\text{Beta}_{X(C)}=2000^*$ filter efficiency; the highest rated filter performance available today.

(* per ISO 16889)

Notes and Specifications Filter Housing

- Flows to 230 L/min (60 US gpm)
- Pressures to 414 bar (6000 psi)
- Port Size 1" and 1¼"
- **Rated Fatigue Pressure:**
0-240 bar (3500 psi) per NFPA T2.06.01R2-2001 CAT C/90/(1 million cycles), verified by testing at 0-280 bar (4050 psi) for 1 million cycles. Contact Pall for applications with higher pressures at lower cycles. Not applicable for D and F Port options.
- **Filter Element Burst Pressure:**
10 bard (150 psid)
- **Fluid Compatibility:**
Compatible with all petroleum oils and most water glycols, water-oil emulsions, and synthetic hydraulic and lubrication fluids
- **Temperature Range:**
Fluorocarbon Seals:
-29 °C to 120 °C (-20 °F to 248 °F)
60 °C (140 °F) maximum in HWCF or water glycol fluids
- **Bypass Valve Setting:**
4.5 bard (65 psid)
- **Indicator Pressure Setting:**
3.5 bard (50 psid)
- **Materials of Construction:**
Head and Cover: Ductile Cast Iron
Tube: Carbon steel
- **Filter Element :**
Inorganic fibers impregnated and bonded with epoxy resins. Polymer endcaps. Anti-static media design

Pressure Drop Information

Housing pressure drop using fluid with 0.9 S.G.

Housing pressure drop is directly proportional to specific gravity.

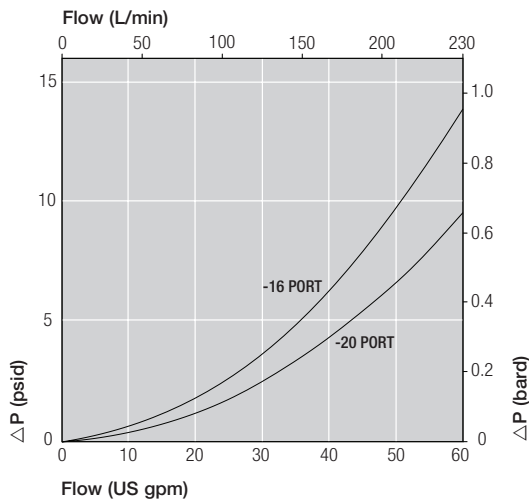

New: UH210 Series Athalon™ High Pressure Filters

- Keeps fluids the cleanest, longest, for the greatest value
- Provides consistent, reliable, protection of system components over the full service life of the filter element
- Rapidly achieves and sustains required fluid system cleanliness
- Delivers maximum filter capacity in the smallest footprint
- Prevents electrostatic discharge from damaging your filter and degrading your fluid

Features

- Patented Ultipleat (laid-over pleat) filter medium pack
- Pall Stress-Resistant Technology (SRT) Media
- Coreless filter element configuration
- Low clean pressure drop for low energy operation



UH210 Series
filter housing

Element Pressure Drop

210 Series Filter Elements – bard/1000 L/min (psid/US gpm)

Length Code	AZ	AP	AN	AS	AT
04	20.07 (1.102)	8.51 (0.467)	5.72 (0.314)	3.55 (0.195)	2.69 (0.029)
08	9.93 (0.545)	4.21 (0.231)	2.83 (0.155)	1.76 (0.096)	1.33 (0.073)
13	5.95 (0.327)	2.52 (0.139)	1.70 (0.093)	1.05 (0.058)	0.80 (0.044)
20	3.95 (0.217)	1.68 (0.092)	1.13 (0.062)	0.70 (0.038)	0.53 (0.029)

Multiply actual flow rate times factor in table below to determine pressure drop with fluid at 32 cSt (150 SUS), 0.9 S.G. Correct for other fluids by multiplying new viscosity in cSt/32 (SUS/150) x new S.G./0.9. Note: factors are per 1000 L/min and per 1 US gpm

Sample ΔP calculation

UH210 Series 13" length housing with C20 BSPP ports using AN grade media. Operating conditions 100 L/min flow rate using a hydraulic fluid of 50 cSt and specific gravity (s.g.) 1.2.

Total Filter ΔP

$$\begin{aligned}
 &= \Delta P_{\text{housing}} + \Delta P_{\text{element}} \\
 &= (0.13 \times 1.2/0.9) \text{ bard (housing)} \\
 &+ ((100 \times 1.70/1000) \times 50/32 \times 1.2/0.9) \text{ bard (element)} \\
 &= 0.17 \text{ (housing)} + 0.35 \text{ bard (element)} \\
 &= \mathbf{0.52 \text{ bard (7.6 psid)}}
 \end{aligned}$$

Ordering Information

For new installations, select one complete part number from each section below

Section 1 Housing P/N: UH210 Table A Table B

Note: Pall Athalon filter housings are supplied without filter elements or warning devices fitted. Never operate the filter unless a filter element is fitted and all warning device ports are sealed.

Note: Z indicates fluorocarbon seals are standard. Other options are available; contact Pall. Housing P/N designates indicator port fitted with a plastic shipping plug.

Table A	Table B
Port & Length Options Tables 1, 2 and 3	Bypass & Orientation Options Tables 4
A1604Z	G or GH
A1608Z	G or GH
A2008Z	G or GH
A2013Z	G or GH
A2020Z	G
C1604Z	G or GH
C1608Z	G or GH
C2008Z	G or GH
C2013Z	G or GH
C2020Z	G
E1604Z	G or GH
E1608Z	G or GH
E2008Z	G or GH
E2013Z	G or GH
E2020Z	G
G1604Z	G or GH
G1608Z	G or GH
G2008Z	G or GH
G2013Z	G or GH
G2020Z	G

Table 1: Housing Port Options

Code	Port Style	Max. Operating Pressure
A	SAE J1926 straight thread	414 bar (6000 psi)
C	BSP ISO 228 threads	414 bar (6000 psi)
E	Flange J518C code 62	414 bar (6000 psi)
G	ISO 6162 split flange	400 bar (5800 psi)

Table 2: Port Size

Code	Port Style
16	1" nominal
20	1 1/4" nominal

Table 3: Housing Length and Seal Options

Code	Length and Seal Material
04Z	4" nominal length, fluorocarbon seals
08Z	8" nominal length, fluorocarbon seals
13Z	13" nominal length, fluorocarbon seals
20Z	20" nominal length, fluorocarbon seals

Table 4: Bypass Valve and Service Options

Code	Bypass Valve and Service Type
G	4.5 bard (65 psid) bypass valve, Cap service
GH	4.5 bard (65 psid) bypass valve, Head service

Seal Kit P/N: SH 210 SKZ

*Other seal material options are available; Contact Pall.

Section 2 Element P/N: UE 210 Table 5 Table 3

Note: Z indicates fluorocarbon seals are standard. Other options are available; contact Pall.

Table 5: Filter Element Options

Code	$\beta_{x(c)} \geq 2000$ based on ISO 16889	CST Rating*
AZ	3	07/04/01
AP	5	11/08/03
AN	7	13/09/04
AS	12	15/11/06
AT	25	16/14/08

* CST: Cyclic Stabilization Test to determine filter rating under stress conditions, based on SAE ARP4205

Section 3 (At least one Differential Pressure Indicator or 'B' type blanking plug must be ordered)

Differential Pressure Indicator P/N:

RC Z091 Z
Table 6 Table 7

Note: If no differential pressure indicator is selected, 'B' type blanking plug (P/N HC9000A104Z) must be ordered separately and fitted to replace the plastic shipping plug.

Note: Z indicates fluorocarbon seals are standard. Other options are available; contact Pall.

Table 6: Indicator Options

Code	Brass Option indicator
A218M	Electrical switch (SPDT) with Hirschmann connector
A218R	Electrical switch (SPDT) with Hirschmann connector with Red and Green LED indicators
A219D	Visual indicator
Code	Stainless Steel indicator
778NZ	Visual filter with thermal lockout
861CZ	Electrical Switch (SPDT) with 6" leads
861CZ*	Electrical switch (SPDT) with Hirschmann connector
771BZ	Electrical switch (SPDT) with 3-pin

Other options available; contact Pall.
 *Requires YM suffix after SS code from Table 7

Table 7: Differential Pressure Indicator Material

Code	Pressure Setting
Omit	Brass Indicator
SS	Stainless Steel Indicator: recommended for high pressure cycle applications with pressure > 200 bar (3000 psi)

Other setting options are available; contact Pall.

Dimensional Drawings

Dimensions in mm (inches)

Length Code	Overall length mm (in)	Cover Service Element Removal Clearance mm (in)	Head Service Element Removal Clearance mm (in)	Empty Weight kg (lb)
04	261.0 (10.28)	147 (5.79)	143 (5.63)	10.3 (22.7)
08	376.5 (14.82)	248 (9.76)	243 (9.57)	12.1 (26.7)
13	511.1 (20.12)	383 (15.08)	380 (14.96)	14.7 (32.4)
20	681.3 (26.82)	553 (21.77)	N/A	17.8 (39.2)

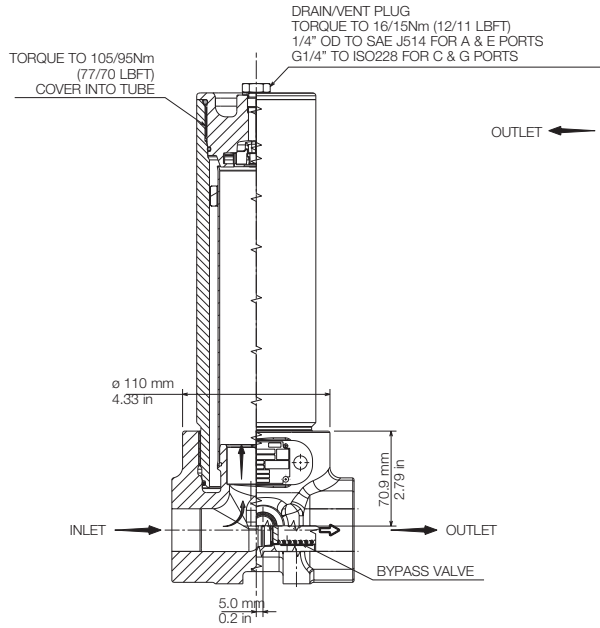
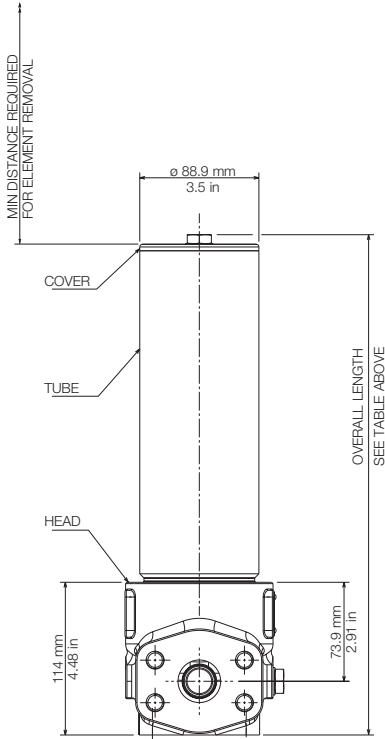

COVER SERVICE

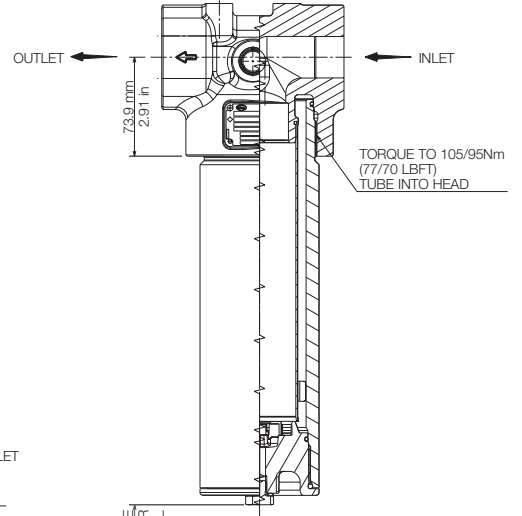

HEAD SERVICE

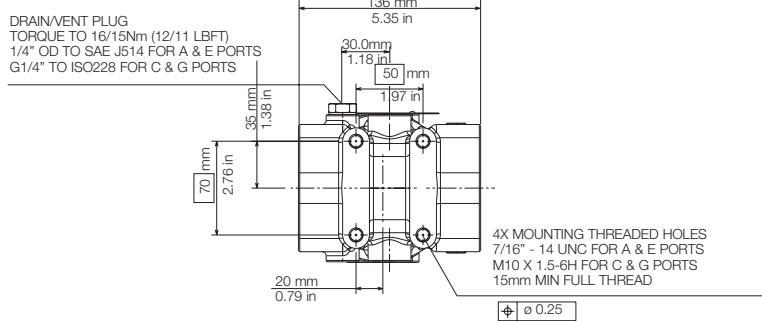

The equipment has been assessed in accordance with the guidelines laid down in The European Pressure Directive 97/23/EC and has been classified within Sound Engineering Practice S.E.P. Suitable for use with Group 1 and 2 fluids only. Consult Sales for other fluid gas group suitability.



25 Harbor Park Drive
 Port Washington NY 11050
 +1 516 484 3600 telephone
 +1 800 289 7255 toll free US

Portsmouth - UK
 +44 (0)23 9233 8000 telephone
 +44 (0)23 9233 8811 fax
 industrialeu@pall.com



Visit us on the Web at www.pall.com

Pall Corporation has offices and plants throughout the world. For Pall representatives in your area, please go to www.pall.com/contact

Because of technological developments related to the products, systems, and/or services described herein, the data and procedures are subject to change without notice. Please consult your Pall representative or visit www.pall.com to verify that this information remains valid.

© Copyright 2015, Pall Corporation. Athalon, Pall and PALL are trademarks of Pall Corporation. ® Indicates a trademark registered in the USA. Better Lives. Better Planet and Filtration. Separation. Solution.sm are service marks of Pall Corporation.