



Pall Corporation

UR219

UR219 Series Filters

ULTIPLEAT® SRT MEDIUM PRESSURE FILTERS

Side Manifold Mounting

Port Size 1¼"



Features

- Unique Ultipleat (laid-over pleat) filter medium pack
- Coreless, cageless element configuration
- Pall Stress-Resistant Technology (SRT) Media
- In-to-out filter element flow path
- Flows to 265 L/min (70 US gpm)
- Pressures to 110 bar (1600 psi)
- Port size 1 1/4"

Notes and Specifications

Filter Housing

- **Maximum Allowable Working Pressure:**
110 bar (1,600 psi)
- **Rated Fatigue Pressure:**
110 bar (1,600 psi)
10⁶ cycles per NFPA T2.06.01R2-2001
- **Fluid Compatibility:**
Compatible with all petroleum oils, water glycols, water-oil emulsions and most synthetic hydraulic and lubrication fluids
- **Temperature Range:**
Fluorocarbon Seals:
-29 °C to 120 °C (-20 °F to 250 °F)
60 °C (140 °F) maximum in HWCF or water glycol fluids
- **Materials of Construction:**
Head and cover: Ductile Iron
Tube: Steel

Filter Element

- **Filter Element Burst Pressure:**
10 bard (150 psid)
- **Ultipleat SRT Element Construction:**
Inorganic fibers impregnated and bonded with epoxy resins. Polymer endcaps. Anti-static media design.

Pressure Drop Information

Housing pressure drop using fluid with 0.9 S.G.

Housing pressure drop is directly proportional to specific gravity.

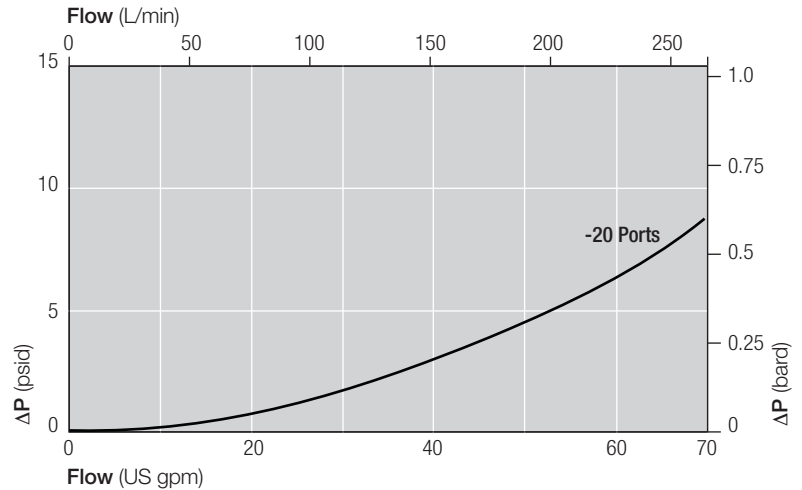

Element Pressure Drop

Multiply actual flow rate times factor in table below to determine pressure drop with fluid at 32 cSt (150 SUS), 0.9 S.G. Correct for other fluids by multiplying new viscosity in cSt/32 (SUS/150) x new S.G./0.9. Note: factors are per 1000 L/min and per 1 US gpm.

219 Series Filter Elements — bard/1000 L/min (psid/US gpm)

Length Code	AZ	AP	AN	AS	AT
08	9.93 (0.545)	4.21 (0.231)	2.83 (0.155)	1.76 (0.096)	1.33 (0.073)
13	5.95 (0.327)	2.52 (0.139)	1.70 (0.093)	1.05 (0.058)	0.80 (0.044)
20	3.95 (0.217)	1.68 (0.092)	1.13 (0.062)	0.70 (0.038)	0.53 (0.029)

Sample ΔP calculation

UR219 Series 13" length housing with S20 (1 1/4") side manifold mount ports using AN grade media. Operating conditions 150 L/min flow rate using a hydraulic fluid of 50 cSt and specific gravity (s.g.) 1.2.

Total Filter ΔP

$$\begin{aligned}
 &= \Delta P \text{ housing} + \Delta P \text{ element} \\
 &= (0.20 \times 1.2/0.9) \text{ bard (housing)} \\
 &+ ((150 \times 1.70/1000) \times 50/32 \times 1.2/0.9) \text{ bard (element)} \\
 &= 0.26 \text{ bard (housing)} + 0.53 \text{ bard (element)} \\
 &= \mathbf{0.79 \text{ bard (11.5 psid)}}
 \end{aligned}$$

The equipment has been assessed in accordance with the guidelines laid down in The European Pressure Directive 97/23/EC and has been classified within Sound Engineering Practice S.E.P. Suitable for use with Group 2 fluids only. Consult Sales for other fluid gas group suitability.

UR219 Series Filters - Manifold Mount

Ordering Information

For new installations, select one complete part number from each section below

Section 1

Housing P/N:

UR 219C S20 ++ 1 Z 2 1 YR85

Note: Pall Ultipleat SRT filter housings are supplied without filter elements or warning devices fitted. Never operate the filter unless a filter element is fitted and all warning device ports are sealed.

Note: Z indicates fluorocarbon seals are standard. Other options are available; contact Pall. The suffix '1' at the end of the Housing P/N designates 1 indicator port, this port will be fitted with a plastic shipping plug.

Seal Kit P/N:

UR 219 SKZ

*Other seal material options are available; Contact Pall.

Table 1: Housing Length Options

Code	Length (in)*
08	8
13	13
20	20

* Nominal length

Table 2: Housing Bypass Valve Options

Code	Valve
A	1.7 bard - 25 psid
G	4.5 bard - 65 psid

Section 2

Element P/N:

UE 219 1 2 Z

Note: Z indicates fluorocarbon seals are standard. Other options are available; contact Pall.

Table 1: Filter Element Options

Code	$\beta_{x(c)} \geq 1000$ based on ISO 16889	CST Rating*
AZ	3	08/04/01
AP	5	12/07/02
AN	7	15/11/04
AS	12	16/13/04
AT	22	17/15/08

* CST: Cyclic Stabilization Test to determine filter rating under stress conditions, based on SAE ARP4205

Table 2: Filter Element Length Options

Code	Length (in)*
08	8
13	13
20	20

* Nominal length

Section 3 (One Differential Pressure Indicator or 'B' type blanking plug must be ordered)

Differential Pressure Indicator P/N:

RC 1 2 Z 3 4

Table 1: Differential Pressure Indicator Options*

Code	Indicator	'H' Dim.
778NZ	'P' type Visual indicator with thermal lockout	21mm (0.83in)
860MZ	'D' type Visual indicator with no thermal lockout	21mm (0.83in)
861CZ	'L' type Electrical switch (SPDT) with 6" leads	38mm (1.50in)
861CZ	'M' type Electrical switch (SPDT) with DIN43650 connector and matching cap	78mm (3.07in)
861CZ	'R' type Electrical switch (SPDT) and neon light indicator with DIN43650 connector and cap	89mm (3.50in)
771BZ	'S' type Electrical switch (SPDT) with 3-pin MS connector	57mm (2.24in)

* Other indicator options are available; contact Pall.

Table 2: Indicator Pressure Setting Options*

Code	Valve
084	For 'A' by-pass valve option (1.1 bard - 16 psid)
091	For 'G' by-pass valve option (3.5 bard - 50 psid)

* Use only if 'R' Indicator is selected from Table 1

Note: If no differential pressure indicator is selected, 'B' type blanking plug (P/N HA9000-P8-Kit Z) must be ordered separately and fitted to replace the plastic shipping plug.

Note: Z indicates fluorocarbon seals are standard. Other options are available; contact Pall.

Table 3: 'M' & 'R'-Type Indicator Codes*

Code	Option
YM	'M' option
YR	'R' option

* Use only if 'R' or 'M' Indicator is selected from Table 1

Table 4: 'R' Indicator Options*

Code	Option
110AC	110V AC
220AC	220V AC
24DC	24V DC

* Use only if 'R' Indicator is selected from Table 1

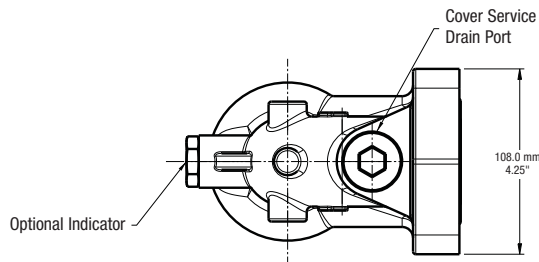
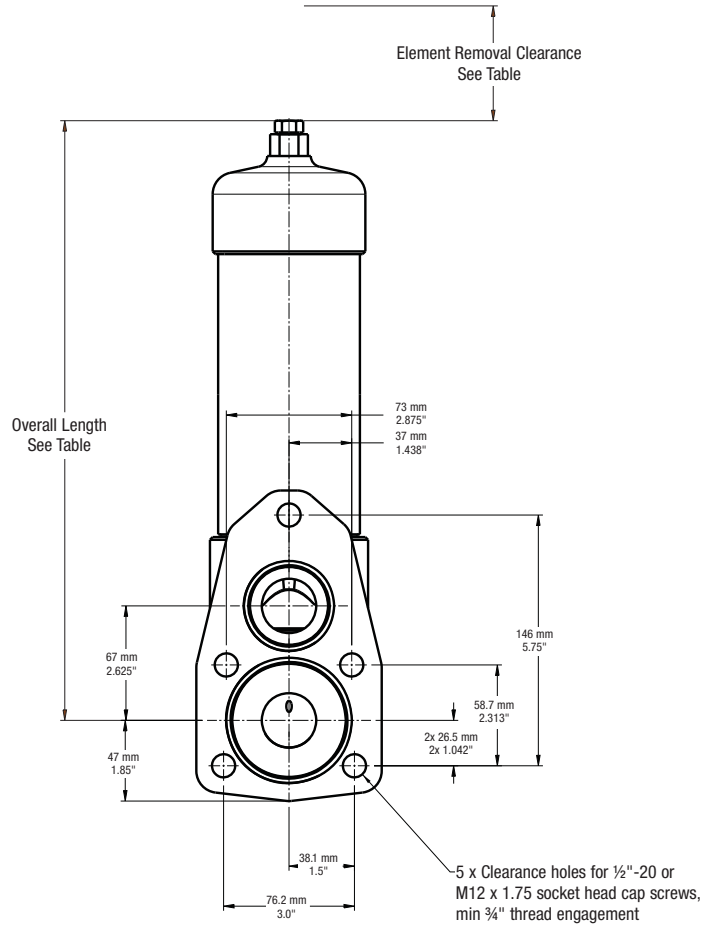
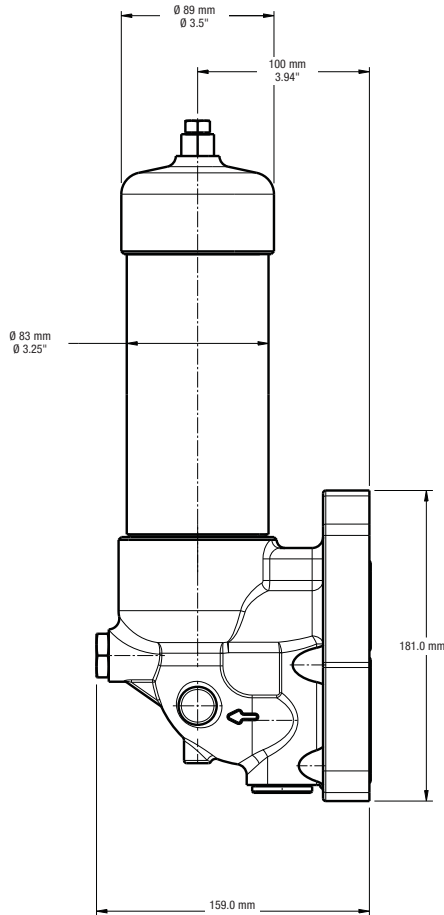

Length Code	Overall Length mm (in)	Element Removal Clearance mm (in)	Empty Weight kg (lb)
08	349 (13.75)	229 (9.0)	35.0 (77.1)
13	484 (19.05)	368 (14.5)	37.4 (82.4)
20	654 (25.75)	533 (21.0)	40.4 (89.1)



Pall Corporation

Pall Industrial Manufacturing

25 Harbor Park Drive
Port Washington, NY 11050
+1 516 484 3600 telephone
+1 800 289 7255 toll free US

Portsmouth-UK
+44 (0)23 9230 3303 telephone
+44 (0)23 9230 2507 fax



Visit us on the Web at www.pall.com

Pall Corporation has offices and plants throughout the world. For Pall representatives in your area, please go to www.pall.com/contact

Because of technological developments related to the products, systems, and/or services described herein, the data and procedures are subject to change without notice. Please consult your Pall representative or visit www.pall.com to verify that this information remains valid. Products in this document may be covered by one or more of the following patent numbers: EP 667,800; EP 982,061; EP 1,380,331; EP 1 656 193; US 5,543,047; US 5,690,765; US 5,725,784; US 6,113,784; US 7,083,564; US 7,318,800; US 7,871,515.

© Copyright 2011, Pall Corporation. Pall, (PALL), and Ultipleat are trademarks of Pall Corporation. ® indicates a trademark registered in the USA. ENABLING A GREENER FUTURE and Filtration. Separation. Solution.sm are service marks of Pall Corporation.