

HIGH PRESSURE FILTERS

DF Series

Inline Filters

6090 psi • up to 200 gpm

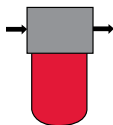

Hydraulic Symbol

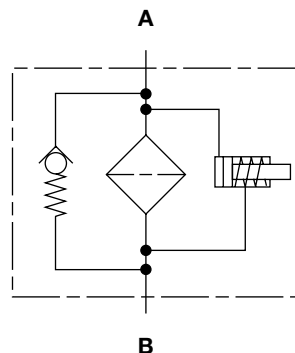

Features

- Non-welded housing design reduces stress concentrations and prevents fatigue failure.
- Choice of NPT, BSPP, SAE straight thread O-ring boss, and SAE 4-bolt flange porting (sizes 60 - 1320) to allow easy installation with maximum flexibility.
- O-ring seals are used to provide positive, reliable sealing. Choice of O-ring materials (nitrile rubber, fluorocarbon elastomer, and ethylene propylene rubber) provides compatibility with petroleum oils, synthetic fluids, water-glycols, oil/water emulsions, and high water based fluids.
- Screw-in bowl or lid (on 2-pc. bowls) mounted below the filter head requires minimal clearance to remove the element for replacement and contaminated fluid cannot be washed downstream when element is serviced.
- HYDAC Differential Pressure Indicators have no external dynamic seal. This results in a high system reliability due to magnetic actuation, thus eliminating a potential leak point.
- A poppet-type bypass valve located in the filter head provides positive sealing during normal operation and fast opening during cold starts and flow surges. *(Optional non-bypass available)*
- For special finishes and coatings – consult HYDAC for minimum quantities, availability and pricing.
- Fatigue pressure ratings equal maximum allowable working pressure rating.

Technical Specifications

Mounting Method	4 mounting holes	
Port Connection	30 SAE-8, 1/2" NPT, 1/2" BSPP 60/110 SAE-12, 3/4" NPT, 3/4" BSPP 3/4" SAE, Code 62 160/240/280 SAE-20, 1 1/4" NPT, 1 1/4" BSPP 1 1/4" SAE, Code 62 330/660/1320 SAE-24, 1 1/2" NPT, 1 1/2" BSPP 2" SAE Flange Code 62	
Flow Direction	Inlet: Side	Outlet: Side
Construction Materials	Head Ductile iron Bowl (30-660) Steel Housing/Bowl (660-1320 - 2.0) Steel Cap/Lid (660-1320 type) Steel	
Flow Capacity	30 8 gpm (30 lpm) 60 16 gpm (60 lpm) 110 29 gpm (110 lpm) 160 42 gpm (160 lpm) 240 63 gpm (240 lpm) 280 74 gpm (280 lpm) 330 87 gpm (330 lpm) 660 174 gpm (660 lpm) 1320 200 gpm (757 lpm)	
Housing Pressure Rating	Max. Allowable Working Pressure 6090 psi (420 bar) Fatigue Pressure 6090 psi (420 bar) @ 1 million cycles Burst Pressure 30 15950 psi (1100 bar) 60/110 17400 psi (1200 bar) 160/240/280 17110 psi (1180 bar) 330/660/1320 15080 psi (1040 bar)	
Element Collapse Pressure Rating	BH4HC, V 3045 psid (210 bar) ON, W/HC 290 psid (20 bar)	
Fluid Temp. Range	14°F to 212°F (-10°C to 100°C) Consult HYDAC for applications operating below 14°F (-10°C)	
Fluid Compatibility	Compatible with all hydrocarbon based, synthetic, water glycol, oil/water emulsion, and high water based fluids when the appropriate seals are selected.	
Indicator Trip Pressure	ΔP = 29 psid (2 bar) -10% (optional) ΔP = 72 psid (5 bar) -10% (standard) ΔP = 116 psid (8 bar) -10% (optional non bypass)	
Bypass Valve Cracking Pressure	ΔP = 43 psid (3 bar) +10% (optional) ΔP = 87 psid (6 bar) +10% (standard) Non Bypass Available	

Applications



Agricultural



Automotive



Construction



Gearboxes

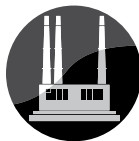

Industrial



Offshore



Commercial Municipal



Power Generation



Pulp & Paper



Railways



Shipbuilding



Steel / Heavy Industry

Model Code

DF ON 30 T B 5 D 1 . X / 12 - V B6 L24

Filter Type _____
 DF = Inline filter

Element Media _____
 ON = Optimicron® BH/HC = Betamicon® (High Collapse)
 W/HC = Wire Mesh V = Metal Fiber

Size _____
 30, 60, 110, 160, 240, 280, 330, 660, 1320

Pressure Range _____
 T = 420 bar

Size and Nominal Connection _____
 B = 1/2" Threaded (size 30 only) I = 3/4" SAE Code 62 Flange (sizes 60-140 only)
 C = 3/4" Threaded (sizes 60-140 only) J = 1 1/4" SAE Code 62 Flange (sizes 160-280 only)
 E = 1 1/4" Threaded (sizes 160-280 only) L = 2" SAE Code 62 Flange (sizes 330-1320 only)
 F = 1 1/2" Threaded (sizes 330-1320 only)

Filtration Rating (microns) _____
 1, 3, 5, 10, 15, 20 = ON 3, 5, 10, 20 = BH/HC 25, 50, 100, 200 = W/HC 3, 5, 10, 20 = V

Type of ΔP Clogging Indicator _____
 A, B, BM, C, D (others available upon request)

Type Number _____
 1 = One piece bowl (sizes 30-660 only) 2 = Two piece bowl (sizes 660-1320 only)
 3 = Upside down mount (two-piece bowl) - (sizes 330-1320)

Modification Number (latest version always supplied) _____

Port Configuration _____
 0 = BSPP
 3 = NPT ports – NPT ported filters will be SAE with adaptors in each port
 12 = SAE straight thread O-ring boss ports
 16 = SAE flange ports (sizes 60-1320 only)

Seals _____
 (omit) = Nitrile rubber (NBR) (standard) V = Fluorocarbon elastomer (FKM) EPR = Ethylene propylene rubber (EPR)

Bypass Valve _____
 (omit) = Non-bypass B3 = Bypass (3 bar) B6 = Bypass (6 bar)

Supplementary Details _____
 SO263 = Modification of elements for Skydrol or HYJET phosphate ester fluids
 SO184 = G-1/2 Drain in Bowl Option For Sizes 60 - 280 (comes standard for sizes 330, 660, & 1320)
 SO210H = Alternate Bowl (sizes 160, 240, & 280) - 16 mm longer
 W = "VD..." indicator modified with a brass piston for use with High water based emulsions/solutions (HFA) & (HFC) or when using "V" elements
 L24, L48, L110, L220 = Lamp for D-type clogging indicator (LXX, XX = voltage)
 T100 = Indicator Thermal Lockout, 100°F (C and D indicators only)
 cRUUs = Electrical Indicators with underwriter's recognition
 SFREE = Element specially designed to minimize electrostatic charge generation

Replacement Element Model Code

0030 D 005 ON / V

Size _____
 0030, 0060, 0110, 0160,
 0240, 0280, 0330, 0660, 1320

Filtration Rating (micron) _____
 3, 5, 10, 20 = BH4HC 1, 3, 5, 10, 15, 20 = ON
 25, 50, 100, 200 = W/HC 3, 5, 10, 20 = V

Element Media _____
 BH4HC, ON, W/HC, V

Seals _____
 (omit) = Nitrile rubber (NBR) (standard)
 V = Fluorocarbon elastomer (FKM)
 EP = Ethylene propylene rubber (EPR)

Supplementary Details _____
 SO263 = (same as above)
 W = Modification of "V" elements for use with oil water emulsions (HFA) and water polymer solutions (HFC) usually polyglycol
 SFREE = (same as above)

Clogging Indicator Model Code

VD 5 D . X / V L24

Indicator Prefix _____
 VD = G 1/2 6000 psi

Trip Pressure _____
 2 = 29 psid (2 bar) (option)
 5 = 72 psid (5 bar) (standard)
 Optional 15 psid (1 bar) & 116 psid (8 bar) available upon request

Type of Indicator _____
 A = No indicator, plugged port
 B = Pop-up indicator (auto reset)
 BM = Pop-up indicator (manual reset)
 C = Electric switch – SPDT
 D = Electric switch and LED light – SPDT

Modification Number _____

Supplementary Details _____

Seals _____
 (omit) = Nitrile rubber (NBR) (standard)
 V = Fluorocarbon elastomer (FKM)
 EP = Ethylene propylene rubber (EPR)

Light Voltage (D type indicators only) _____
 L24 = 24V L110 = 110V

Thermal Lockout (VM, VD types C, D, J, and J4 only) _____
 T100 = Lockout below 100°F

Underwriters Recognition (VM, VD types C, D, J, and J4 only) _____
 cRUUs = Electrical Indicators with underwriter's recognition
 W = "VD..." indicator modified with a brass piston for use with High water based emulsions/solutions (HFA) & (HFC)
 (For additional details and options, see Section H - Clogging Indicators.)

Model Codes Containing RED are non-stock items – Minimum quantities may apply – Contact HYDAC for information and availability

HIGH PRESSURE FILTERS

Dimensions DF 30

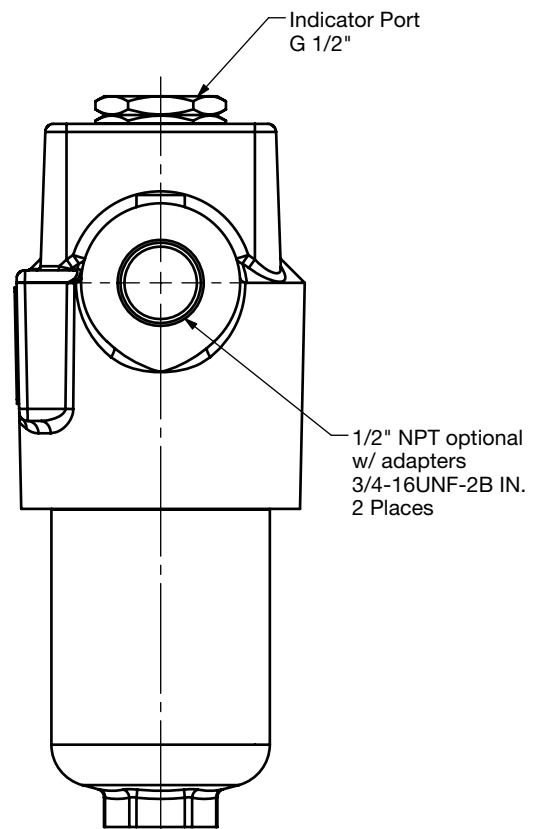
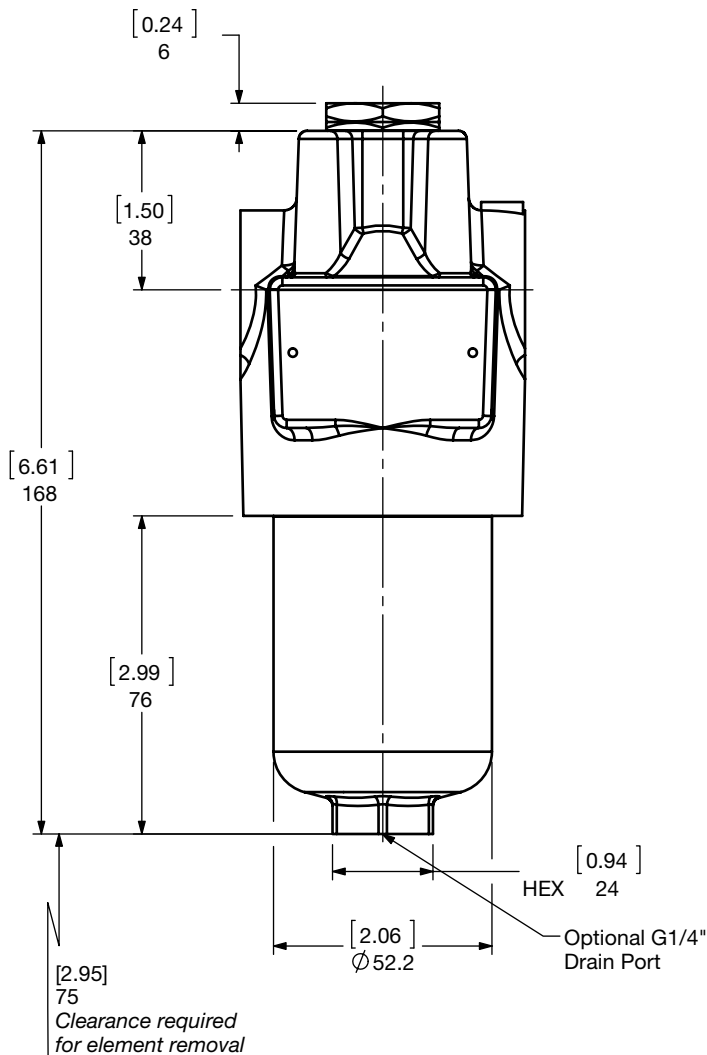
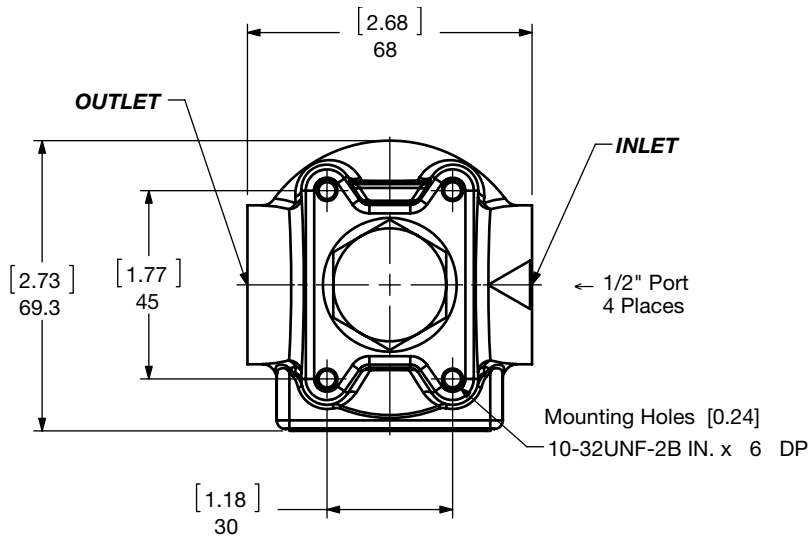

Size	30
Weight (lbs.)	5.1

Dimensions shown are [inches] millimeters for general information and overall envelope size only. Weights listed include element. For complete dimensions please contact HYDAC to request a certified print.

Dimensions DF 60-330

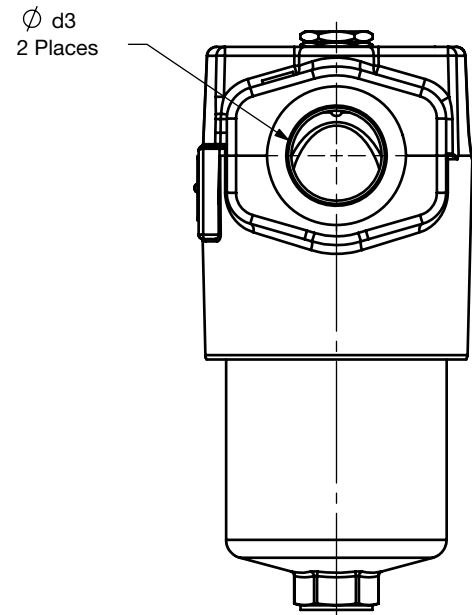
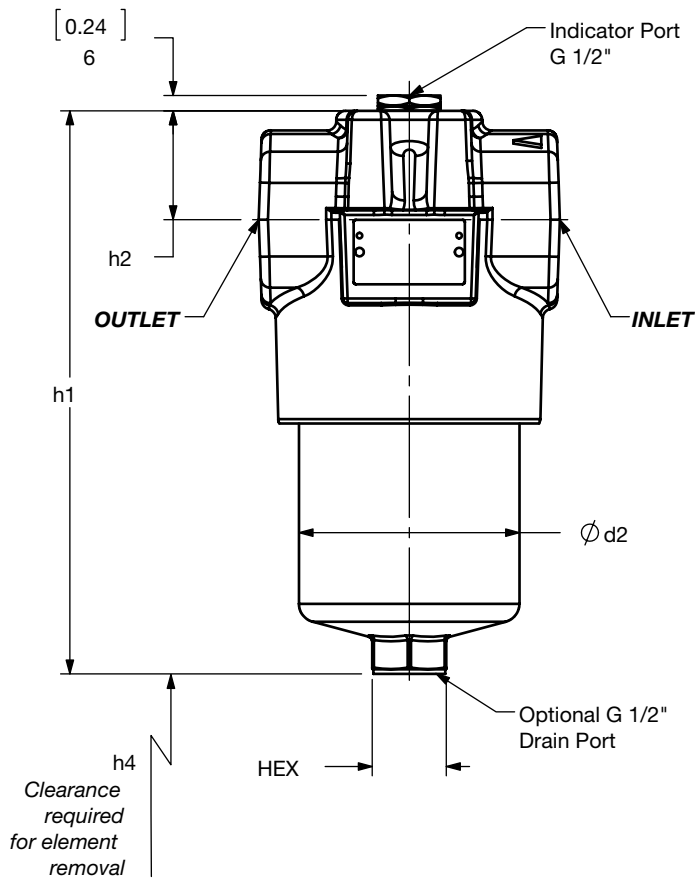
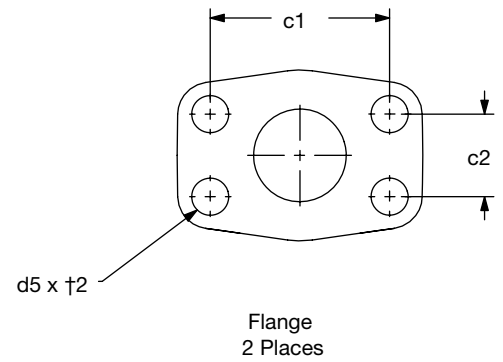
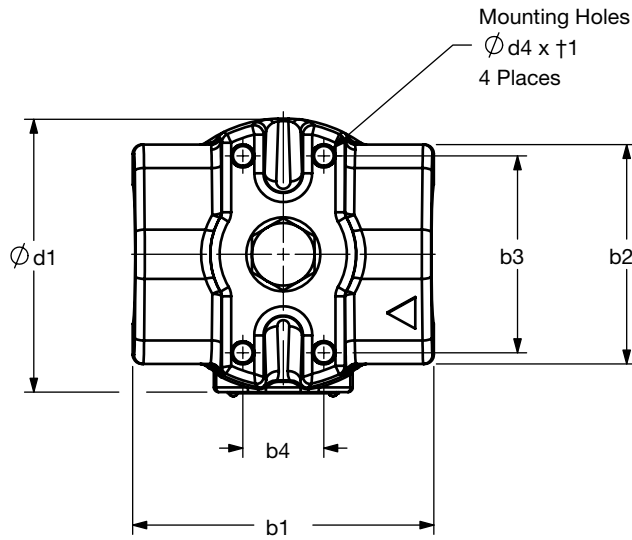

Size	60	110	160	240	280	330
Weight (lbs.)	10	12	22.8	26.1	36	54.1

Dimensions shown are [inches] millimeters for general information and overall envelope size only. Weights listed include element. For complete dimensions please contact HYDAC to request a certified print.

HIGH PRESSURE FILTERS

Dimensions

DF 60-330 (cont'd)

Size	b1	b2	b3	b4	c1	c2	d1	d2	d3 NOM	d4*	d5	h1	h2	h4	HEX	†1	†2
60...C... 1.X	(3.54) 90	(2.8) 71	(2.2) 56	(1.26) 32	-	-	(3.39) 86	(2.68) 68	3/4"	1/4- 28UNF- 2B M6x1.0	-	(7.22) 183.5	(1.57) 40	(3.35) 85	(1.06) 27	(0.35) 9	-
60...L... 1.X	(3.50) 89	(2.8) 71	(2.2) 56	(1.26) 32	(2.00) 50.8	(0.94) 23.8	(3.39) 86	(2.68) 68			3/8- 16UNC- 2B M10 X 1.5	(7.22) 183.5	(1.57) 40	(3.35) 85	(1.06) 27	(0.35) 9	(0.59) 15
110...C... 1.X	(3.54) 90	(2.8) 71	(2.2) 56	(1.26) 32	-	-	(3.39) 86	(2.68) 68	3/4"	1/4- 28UNF- 2B M6x1.0	-	(9.88) 251	(1.57) 40	(3.35) 85	(1.06) 27	(0.35) 9	-
110...L... 1.X	(3.50) 89	(2.8) 71	(2.2) 56	(1.26) 32	(2.00) 50.8	(0.94) 23.8	(3.39) 86	(2.68) 68			3/8- 16UNC- 2B M10 X 1.5	(9.88) 251	(1.57) 40	(3.35) 85	(1.06) 27	(0.35) 9	(0.59) 15
160...E... 1.X	(4.92) 125	(3.74) 95	(3.35) 85	(1.38) 35	-	-	(4.69) 119	(3.74) 95	1- 1/4"	3/8- 24UNF- 2B M10x1.5	-	(9.57) 243	(1.85) 47	(4.13) 105	(1.26) 32	(0.55) 14	-
160...J... 1.X	(4.92) 125	(3.74) 95	(3.35) 85	(1.38) 35	(2.63) 66.7	(1.25) 31.8	(4.69) 119	(3.74) 95			1/2- 13UNC- 2B M14 X 2	(9.57) 243	(1.85) 47	(4.13) 105	(1.26) 32	(0.55) 14	(0.75) 19
240...E... 1.X	(4.92) 125	(3.74) 95	(3.35) 85	(1.38) 35	-	-	(4.69) 119	(3.74) 95	1- 1/4"	3/8- 24UNF- 2B M10x1.5	-	(11.91) 302.5	(1.85) 47	(4.13) 105	(1.26) 32	(0.55) 14	-
240...J... 1.X	(4.92) 125	(3.74) 95	(3.35) 85	(1.38) 35	(2.63) 66.7	(1.25) 31.8	(4.69) 119	(3.74) 95			1/2- 13UNC- 2B M14 X 2	(11.91) 302.5	(1.85) 47	(4.13) 105	(1.26) 32	(0.55) 14	(0.75) 19
280...E... 1.X	(4.92) 125	(3.74) 95	(3.35) 85	(1.38) 35	-	-	(4.69) 119	(3.74) 95	1- 1/4"	3/8- 24UNF- 2B M10x1.5	-	(19.06) 484	(1.85) 47	(4.13) 105	(1.26) 32	(0.55) 14	-
280...J... 1.X	(4.92) 125	(3.74) 95	(3.35) 85	(1.38) 35	(2.63) 66.7	(1.25) 31.8	(4.69) 119	(3.74) 95			1/2- 13UNC- 2B M14 X 2	(19.06) 484	(1.85) 47	(4.13) 105	(1.26) 32	(0.55) 14	(0.75) 19
330...F... 1.X	(6.30) 160	(5.24) 133	(4.53) 115	(2.36) 60	-	-	(6.42) 163	(5.12) 130	2"	1/2- 20UNF- 2B M12x1.75	-	(12.16) 309	(2.05) 52	(4.53) 115	(1.42) 36	(0.67) 17	-
330...L... 1.X	(6.30) 160	(5.24) 133	(4.53) 115	(2.36) 60	(3.81) 96.8	(1.75) 44.5	(6.42) 163	(5.12) 130			3/4- 10UNC- 2B M20 X 2.5	(12.16) 309	(2.05) 52	(4.53) 115	(1.42) 36	(0.67) 17	(0.98) 25
330...F... 2.X	(6.30) 160	(5.24) 133	(4.53) 115	(2.36) 60	-	-	(6.42) 163	(5.12) 130	2"	1/2- 20UNF- 2B M12x1.75	-	(12.16) 309	(2.05) 52	(7.09) 180	(1.42) 36	(0.67) 17	-
330...L... 2.X	(6.30) 160	(5.24) 133	(4.53) 115	(2.36) 60	(3.81) 96.8	(1.75) 44.5	(6.42) 163	(5.12) 130			3/4- 10UNC- 2B M20 X 2.5	(12.16) 309	(2.05) 52	(7.09) 180	(1.42) 36	(0.67) 17	(0.98) 25

*d4 - UN Threads for SAE (/12) & Flanged (/16) ports
 - M Threads for BSPP ports & Flanged metric ports

Notes



Dimensions DF 660-1320

660 1.0 Version

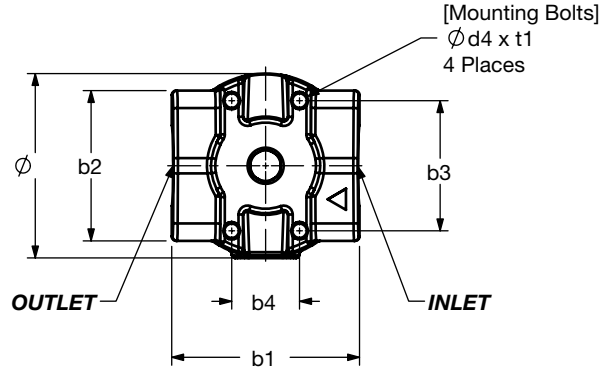

660-1320 2.0 Version

Note - See 1.X Version for mounting

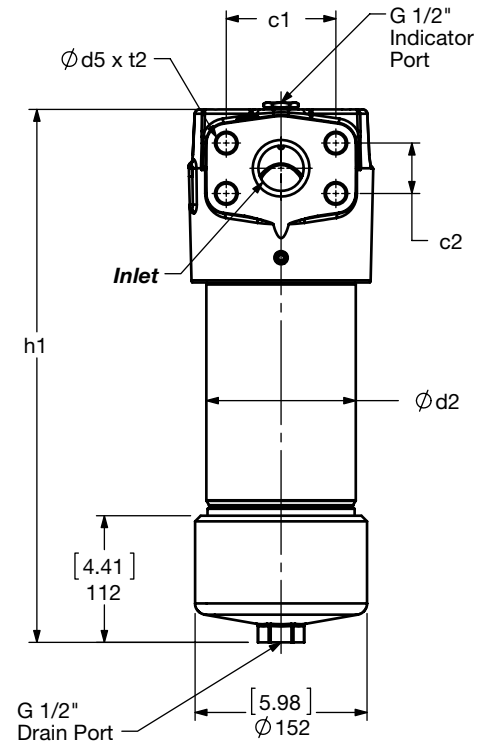
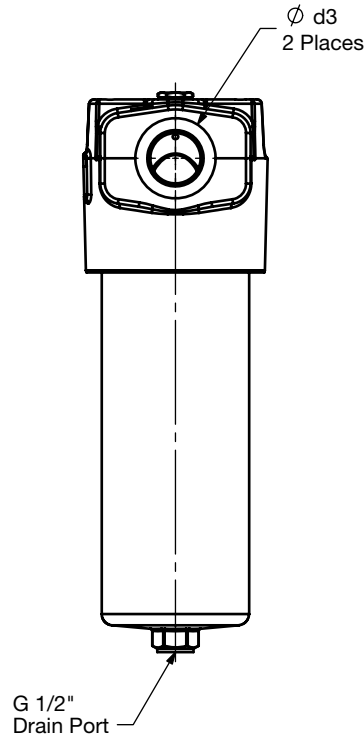
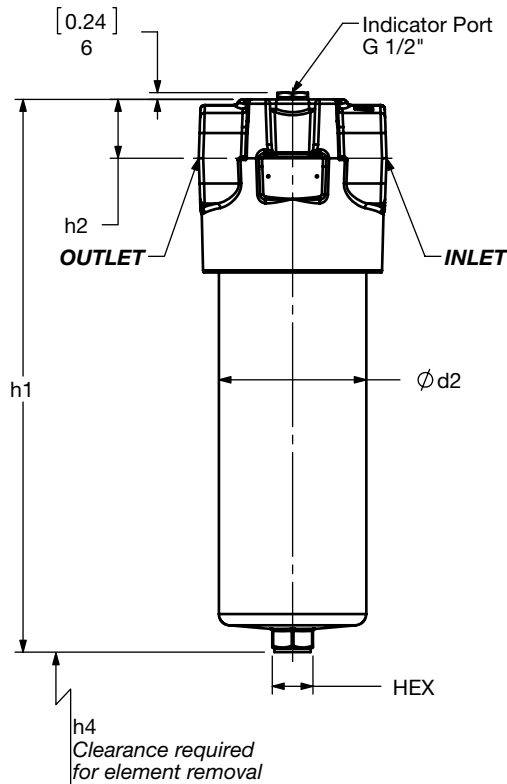
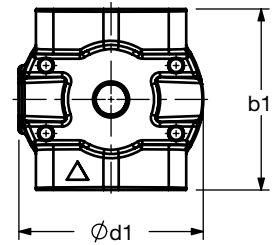

Size	b1	b2	b3	b4	c1	c2	d1	d2	d3 NOM	d4*	d5	h1	h2	h4	HEX	†1	†2
660...F... 1.X	(6.3) 160	(5.24) 133	(4.53) 115	(2.36) 60	-	-	(6.42) 163	(5.12) 130	1- 1/2"	1/2-	-	(18.93) 481	(2.05) 52	(4.53) 115	(1.42) 36	(0.67) 17	-
660...L... 1.X	(6.3) 160	(5.24) 133	(4.53) 115	(2.36) 60	(3.81) 96.8	(1.75) 44.5	(6.42) 163	(5.12) 130	2"	20UNF- 2B M12x1.75	3/4- 10UNC- 2B M20x2.5	(18.93) 481	(2.05) 52	(4.53) 115	(1.42) 36	(0.67) 17	(0.98) 25
660...F... 2.X	(6.3) 160	(5.24) 133	(4.53) 115	(2.36) 60	-	-	(6.42) 163	(5.12) 130	1- 1/2"	1/2-	-	(18.54) 471	(2.05) 52	(13.78) 350	(1.42) 36	(0.67) 17	-
660...L... 2.X	(6.3) 160	(5.24) 133	(4.53) 115	(2.36) 60	(3.81) 96.8	(1.75) 44.5	(6.42) 163	(5.12) 130	2"	20UNF- 2B M12x1.75	3/4- 10UNC- 2B M20x2.5	(18.54) 471	(2.05) 52	(13.78) 350	(1.42) 36	(0.67) 17	(0.98) 25
1320...F... 2.X	(6.3) 160	(5.24) 133	(4.53) 115	(2.36) 60	-	-	(6.42) 163	(5.12) 130	1- 1/2"	1/2-	-	(29.25) 743	(2.05) 52	(26.38) 670	(1.42) 36	(0.67) 17	-
1320...L... 2.X	(6.3) 160	(5.24) 133	(4.53) 115	(2.36) 60	(3.81) 96.8	(1.75) 44.5	(6.42) 163	(5.12) 130	2"	20UNF- 2B M12x1.75	3/4- 10UNC- 2B M20x2.5	(29.25) 743	(2.05) 52	(26.38) 670	(1.42) 36	(0.67) 17	(0.98) 25

Size	660 1.0	660 2.0	1320 2.0
Weight (lbs.)	70	75.9	112.7

Dimensions shown are [inches] millimeters for general information and overall envelope size only. Weights listed include element. For complete dimensions please contact HYDAC to request a certified print.

HIGH PRESSURE FILTERS

Dimensions

DF 330/660/1320 3.0 Version

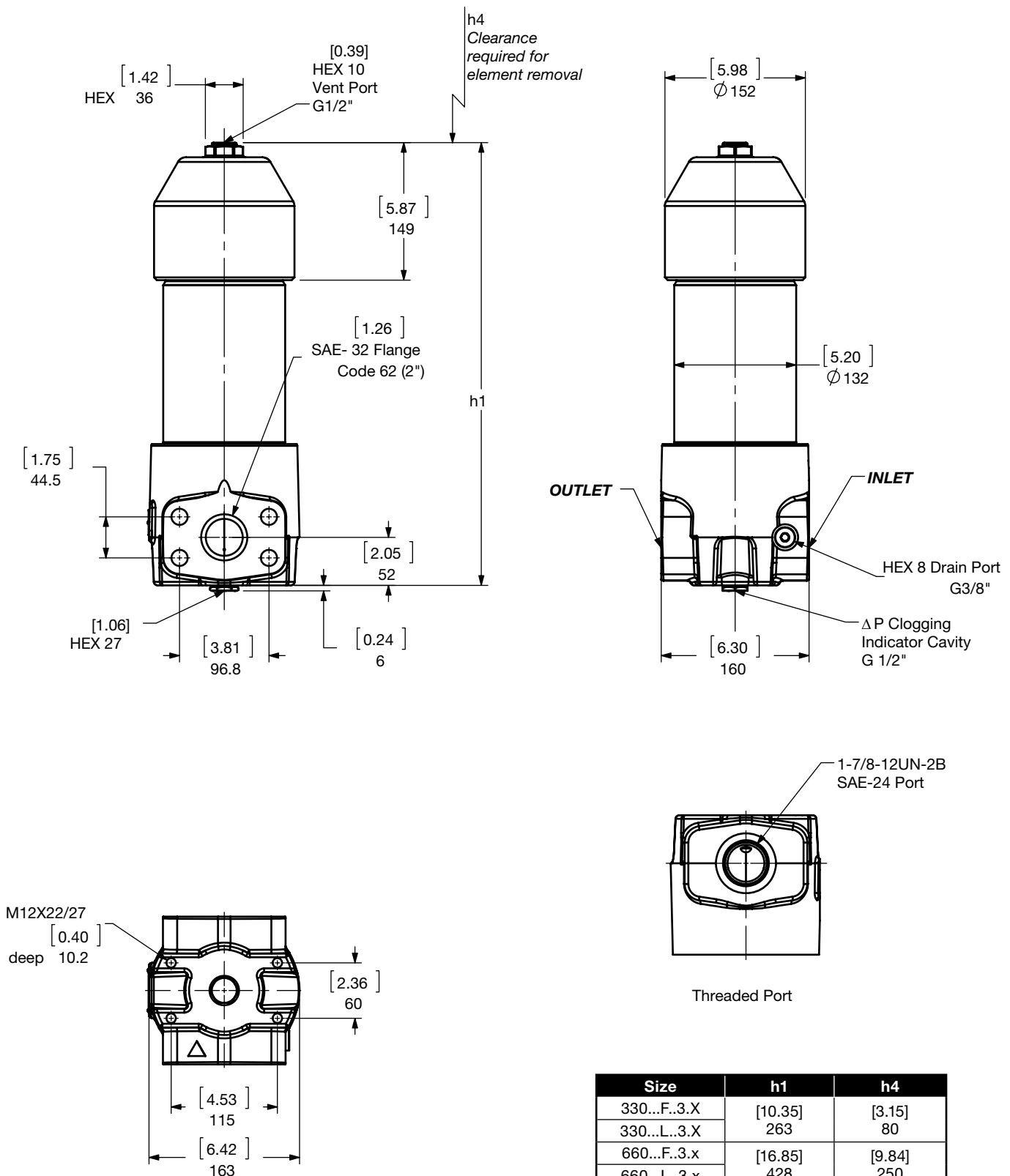

Size	h1	h4
330...F..3.X	[10.35]	[3.15]
330...L..3.X	263	80
660...F..3.x	[16.85]	[9.84]
660...L..3.x	428	250
1320...F..3.x	[29.49]	[22.44]
1320...L..3.x	749	570

Size	330	660	1320
Weight (lbs.)	61.5	74.8	112.0

Dimensions shown are [inches] millimeters for general information and overall envelope size only. Weights listed include element.
For complete dimensions please contact HYDAC to request a certified print.

Sizing Information

Total pressure loss through the filter is as follows:

$$\text{Assembly } \Delta P = \text{Housing } \Delta P + \text{Element } \Delta P$$

Housing Curve:

Pressure loss through housing is as follows:

$$\text{Housing } \Delta P = \text{Housing Curve } \Delta P \times \frac{\text{Actual Specific Gravity}}{0.86}$$

Adjustments must be made for viscosity & specific gravity of the fluid to be used! (see "Sizing HYDAC Filter Assemblies" in Section B - Overview)

DF 30 Housing

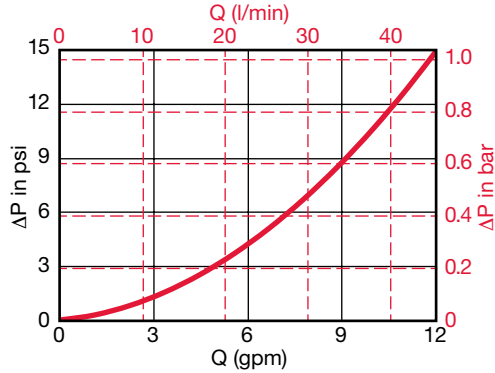

DF 60/110 Housing

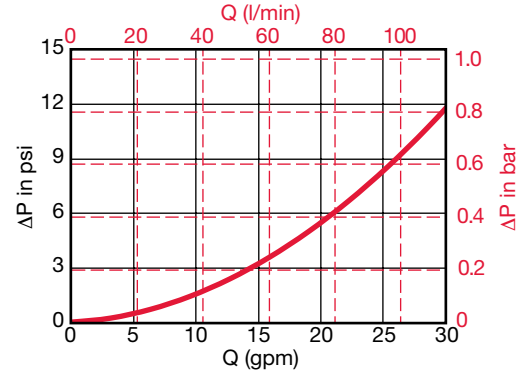

DF 160/240/280 Housing

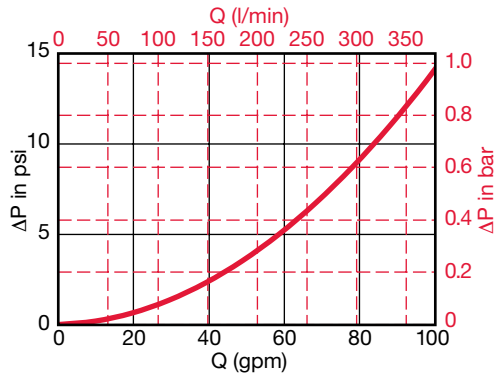

DF 330/660/1320 Housing

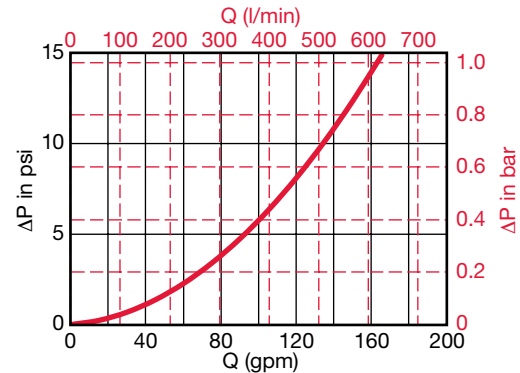

Element K Factors

$$\Delta P \text{ Elements} = \text{Elements (K)} \times \text{Flow Rate (gpm)} \times \frac{\text{Actual Viscosity (SUS)}}{141 \text{ SUS}} \times \frac{\text{Actual Specific Gravity}}{0.86}$$

(From Tables Below)

Betamicon® Size	...D...BH4HC Elements (High Collapse)			
	3 μm	5 μm	10 μm	20 μm
0030 D XXX BH4HC	5.005	2.782	1.992	1.043
0060 D XXX BH4HC	3.216	1.789	0.993	0.670
0110 D XXX BH4HC	1.394	0.818	0.489	0.307
0160 D XXX BH4HC	0.922	0.571	0.324	0.241
0240 D XXX BH4HC	0.582	0.373	0.214	0.159
0280 D XXX BH4HC	0.313	0.187	0.099	0.088
0330 D XXX BH4HC	0.423	0.247	0.154	0.110
0660 D XXX BH4HC	0.181	0.104	0.055	0.049
1320 D XXX BH4HC	0.088	0.055	0.033	0.022

Optimicon Size	...D...ON Elements					
	1 μm	3 μm	5 μm	10 μm	15 μm	20 μm
0030 D XXX ON	4.27	3.507	2.376	1.251	0.768	0.62
0060 D XXX ON	2.936	1.427	1.004	0.664	0.537	0.347
0110 D XXX ON	1.416	0.735	0.527	0.333	0.254	0.164
0160 D XXX ON	1.015	0.604	0.423	0.225	0.204	0.175
0240 D XXX ON	0.631	0.379	0.293	0.175	0.134	0.115
0280 D XXX ON	0.304	0.185	0.15	0.082	0.075	0.064
0330 D XXX ON	0.452	0.23	0.185	0.135	0.085	0.067
0660 D XXX ON	0.207	0.106	0.086	0.051	0.039	0.031
1320 D XXX ON	0.102	0.053	0.042	0.025	0.019	0.015

Wire Mesh Size	...D...W/HC Elements
	25, 50, 100, 200 μm
0030 D XXX W/HC	0.166
0060 D XXX W/HC	0.042
0110 D XXX W/HC	0.023
0160 D XXX W/HC	0.016
0240 D XXX W/HC	0.010
0280 D XXX W/HC	0.005
0330 D XXX W/HC	0.008
0660 D XXX W/HC	0.004
1320 D XXX W/HC	0.002

Metal Fiber Size	...D...V Elements (High Collapse)			
	3 μm	5 μm	10 μm	20 μm
0030 D XXX V	1.011	0.740	0.411	0.200
0060 D XXX V	0.877	0.511	0.296	0.183
0110 D XXX V	0.452	0.304	0.182	0.118
0160 D XXX V	0.251	0.177	0.123	0.079
0240 D XXX V	0.169	0.137	0.093	0.062
0280 D XXX V	0.126	0.093	0.064	0.041
0330 D XXX V	0.121	0.097	0.065	0.043
0660 D XXX V	0.063	0.050	0.034	0.021
1320 D XXX V	0.032	0.026	0.018	0.012

All Element K Factors in psi / gpm.