

HIGH PRESSURE FILTERS

DF...QE Series

Manifold Mount Filters

4568 psi • up to 110 gpm



Hydraulic Symbol

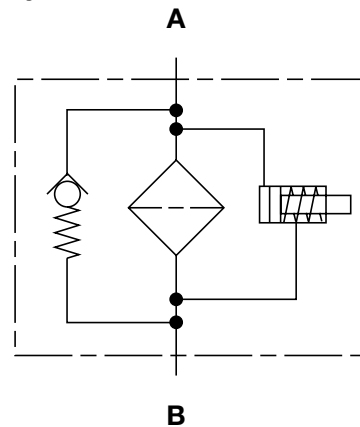

Features

- The DF...QE Filters have a filter head of ductile iron and a screw-in bowl of cold-formed steel for high fatigue strength.
- The filter housings are designed to withstand pressure surges as well as high static pressure loads.
- The screw-in bowl or lid/cap allows the filter element to be easily removed for replacement or cleaning.
- Visual (pop-up), electrical, electrical/visual (lamp), or electronic differential type clogging indicators can be installed.
- DF...QE filters are available with or without a bypass valve located in filter head, so either high or low collapse pressure elements may be used.
- Fatigue pressure rating equals maximum allowable working pressure rating.

Technical Specifications

Mounting Method	4 mounting holes (<i>manifold mount</i>)	
Port Connection	Diameters	
30	0.551" (14mm)	
60/110	0.787" (20mm)	
160/240/280	1.260" (32mm)	
330/660/1320	1.181" (30mm)	
Flow Direction	Inlet: Side	Outlet: Side
Construction Materials		
Head	Ductile iron	
Single piece bowl "1.X"		
Bowl	Steel	
Two piece bowl "2.X"		
Housing	Steel	
Lid/Cap	Steel	
Flow Capacity		
30	8 gpm (30 lpm)	
60	16 gpm (60 lpm)	
110	29 gpm (110 lpm)	
160	42 gpm (160 lpm)	
240	63 gpm (240 lpm)	
280	74 gpm (280 lpm)	
330	87 gpm (330 lpm)	
660	100 gpm (378.5 lpm)	
1320	110 gpm (416.4 lpm)	
Housing Pressure Rating	QE	MHE
Max. Allowable Working Pressure	4568 psi (315 bar)	3625 psi (250 bar)
Fatigue Pressure	4568 psi (315 bar) @ 1 mil. cycles	3625 psi (250 bar) @ 100 mil. cycles
Burst Pressure	Contact HYDAC	
Element Collapse Pressure Rating		
BH4HC, V	3045 psid (210 bar)	
ON, W/HC	290 psid (20 bar)	
Fluid Temperature Range	14°F to 212°F (-10°C to 100°C) Consult HYDAC for applications operating below 14°F (-10°C)	
Fluid Compatibility	Compatible with all hydrocarbon based, synthetic, water glycol, oil/water emulsion, and high water based fluids when the appropriate seals are selected.	
Indicator Trip Pressure		
	$\Delta P = 29$ psid (2 bar) -10% (<i>optional</i>)	
	$\Delta P = 72$ psid (5 bar) -10% (<i>standard</i>)	
Bypass Valve Cracking Pressure		
	$\Delta P = 43$ psid (3 bar) +10% (<i>optional</i>)	
	$\Delta P = 87$ psid (6 bar) +10% (<i>standard</i>)	

Applications



Industrial



Railways



Steel / Heavy Industry

Model Code

DF BH/HC 30 Q E 3 B 1 . X /

Filter Type _____
DF

Element Media _____
ON = Optimicron® (Low Collapse) BH/HC = Betamicon® (High Collapse)
V = Metal Fiber W/HC = Wire Mesh

Size _____
30, 60, 110, 160, 240, 280, 330, 660, 1320

Operating Pressure _____
Q = 4500 psi (300 bar)
MH = 3625 psi (250 bar) (high dynamic @ 100 million cycles)

Type of Connection _____
E = Manifold Block Mounting - Side of Filter Head - 4 mounting holes

Filtration Rating (microns) _____
3, 5, 10, 20 = BH/HC 1, 3, 5, 10, 15, 20 = ON 3, 5, 10, 20 = V 25, 50, 100, 200 = W/HC

Type of ΔP Clogging Indicator _____
A, B, BM, C, D (Others available upon request)

Type Number _____
1 = Filters with one piece bowls (sizes 30-660)
2 = Filters with two piece bowls (sizes 660-1320)

Modification Number (the latest version is always supplied) _____

Seals _____
(omit = Nitrile rubber (NBR) (standard) V = Fluorocarbon elastomer (FKM) EPR = Ethylene propylene rubber (EPR)

Bypass Valve _____
(omit) = Without Bypass (BH4HC or V elements recommended)
B3 = 43 psid Bypass (optional)
B6 = 87 psid Bypass (standard)

Supplementary Details _____
SO263 = Modification of elements for Skydrol or HYJET phosphate ester fluids
SO184 = G-1/2 Drain in Bowl Option For Sizes 30 - 280 (standard for sizes 330 - 1320)
W = "VD..." indicator modified with a brass piston for use with high water based emulsions/solutions (HFA) & (HFC)
L24, L48, L110, L220 = Lamp for D-type clogging indicator (LXX, XX = voltage)
T100 = Indicator Thermal Lockout, 100°F (C and D indicators only)
SFREE = Element specially designed to minimize electrostatic charge generation
cRUUs = Electrical Indicator with underwriter's recognition

Replacement Element Model Code

0030 D 003 BH4HC /

Size _____
0030, 0060, 0110, 0160, 0240,
0280, 0330, 0660, 1320

Filtration Rating (micron) _____
3, 5, 10, 20 = BH4HC
1, 3, 5, 10, 15, 20 = ON
3, 5, 10, 20 = V
25, 50, 100, 200 = W/HC

Element Media _____
BH4HC, ON, V, W/HC

Seals _____
(omit) = Nitrile rubber (NBR) (standard)
V = Fluorocarbon elastomer (FKM)
EPR = Ethylene propylene rubber (EPR)

Supplementary Details _____
SO263 = (same as above)
SFREE = (same as above)

Clogging Indicator Model Code

VD 5 B . X /

Indicator Prefix _____
VD = G 1/2 6000 psi

Trip Pressure _____
2 = 29 psid (2 bar) (option)
5 = 72 psid (5 bar) (standard)
Optional 116 psid (8 bar) available upon request

Type of Indicator _____
A = No indicator, plugged port
B = Pop-up indicator (auto reset)
BM = Pop-up indicator (manual reset)
C = Electric switch - SPDT
D = Electric switch and LED light - SPDT

Modification Number _____

Supplementary Details _____

Seals _____
(omit) = Nitrile rubber (NBR) (standard)
V = Fluorocarbon elastomer (FKM)
EPR = Ethylene propylene rubber (EPR)

Light Voltage (D type indicators only) _____
L24 = 24V L110 = 110V

Thermal Lockout (VM, VD types C, D, J, and J4 only) _____
T100 = Lockout below 100°F

Underwriters Recognition (VM, VD types C, D, J, and J4 only) _____
cRUUs = Electrical Indicator with underwriter's recognition

W = "VD..." indicator modified with a brass piston for use with high water based emulsions/solutions (HFA) & (HFC)
(For additional details and options, see Section H - Clogging Indicators.)

Model Codes Containing RED are non-stock items — Minimum quantities may apply — Contact HYDAC for information and availability

HIGH PRESSURE FILTERS

Dimensions

DF 30 – 280 QE 1.X

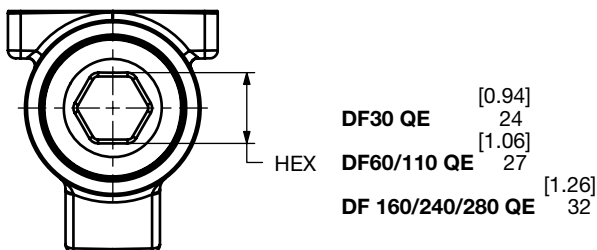
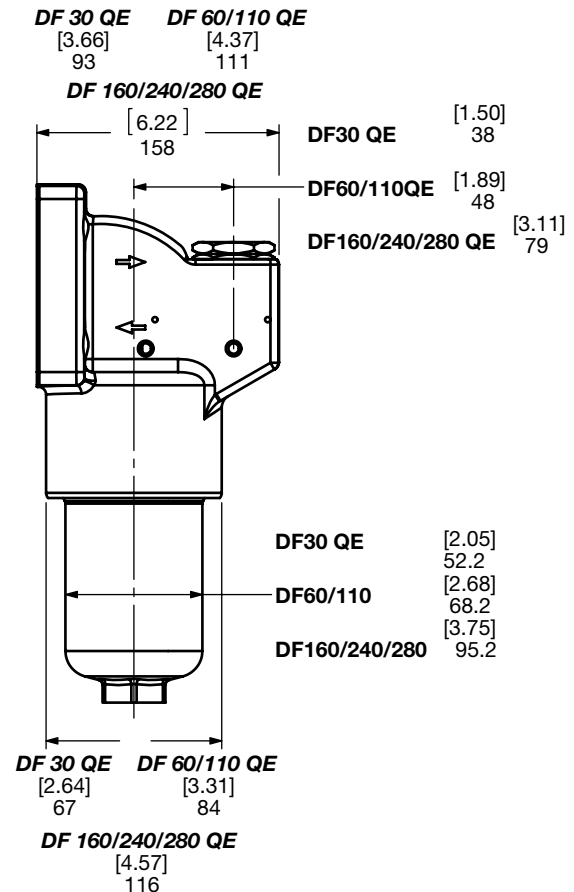
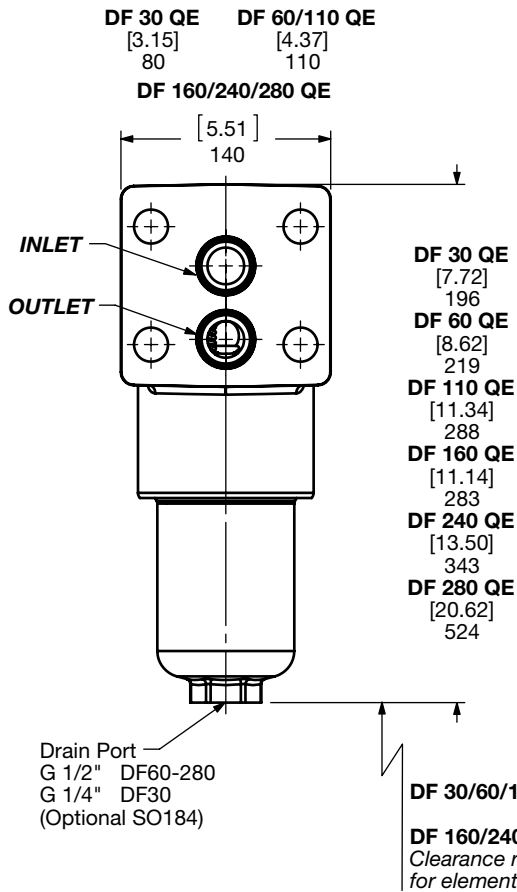
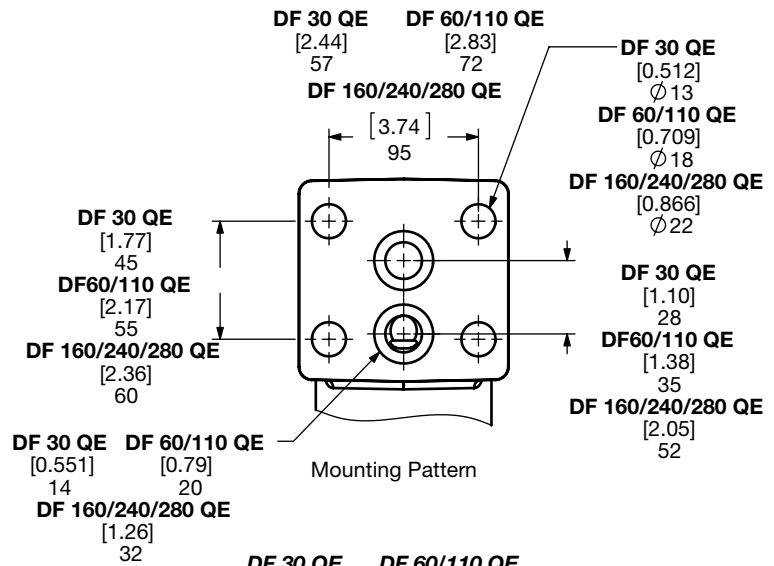
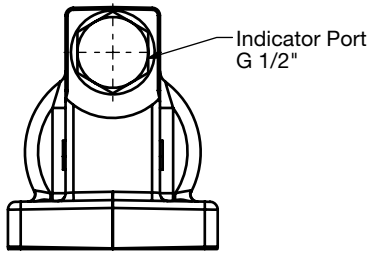

Size	30	60	110	160	240	280
Weight (lbs.)	6.4	11.5	13.5	21.2	25.6	35.1

Dimensions shown are [inches] millimeters for general information and overall envelope size only. Weights listed include element.
For complete dimensions please contact HYDAC to request a certified print.

Dimensions DF 330 – 660 QE 1.X

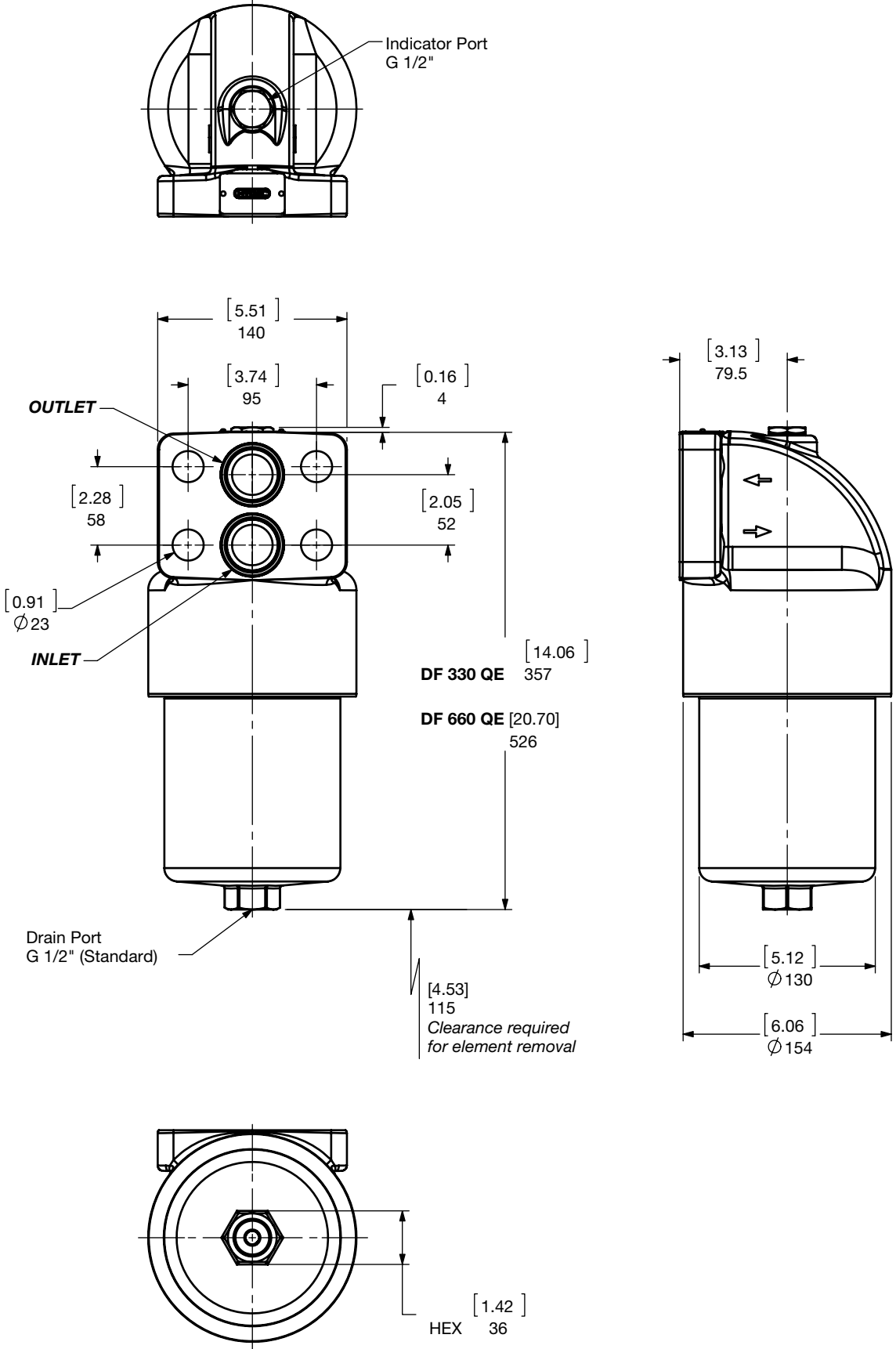

Size	330	660
Weight (lbs.)	50.5	75.2

Dimensions shown are [inches] millimeters for general information and overall envelope size only. Weights listed include element. For complete dimensions please contact HYDAC to request a certified print.

HIGH PRESSURE FILTERS

Dimensions

DF 660 – 1320 QE 2.X

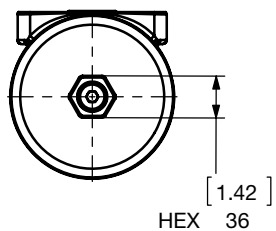
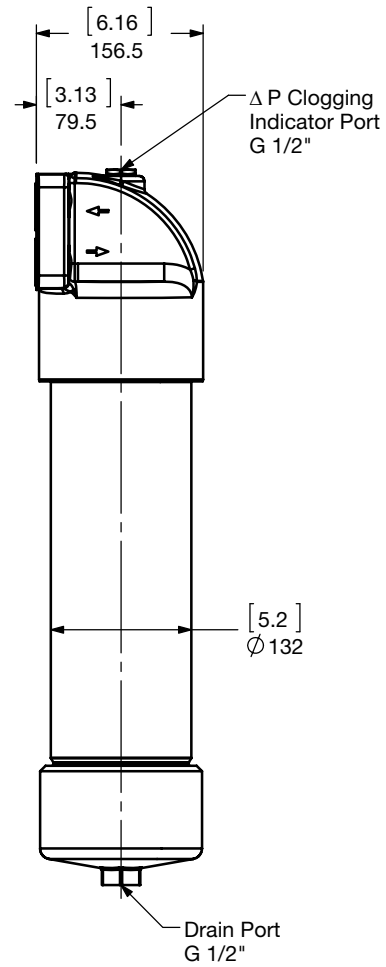
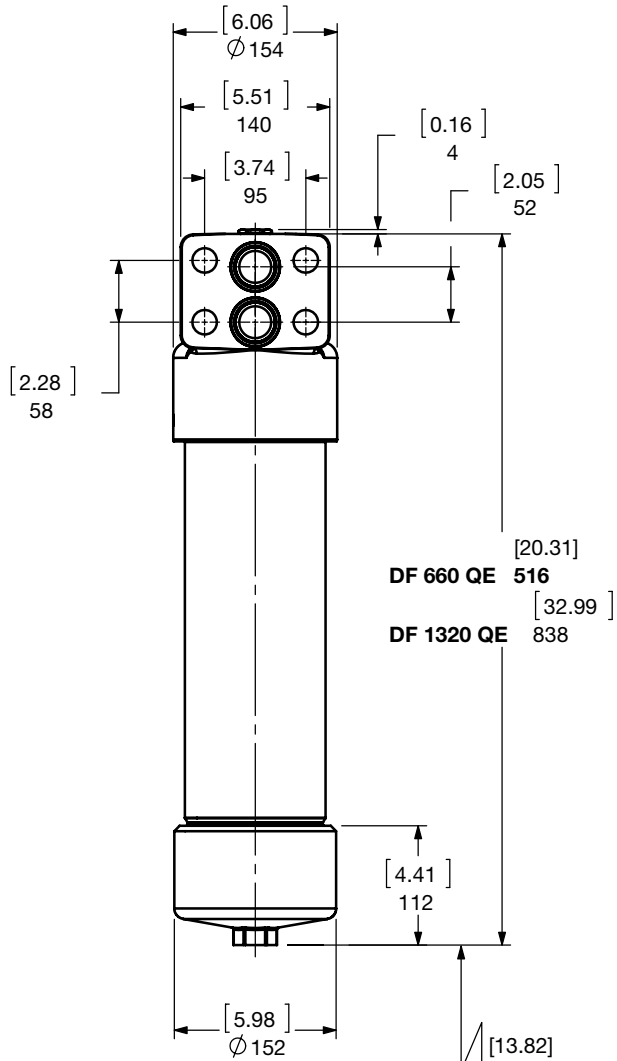
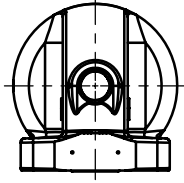

[13.82] 351 **DF 660 QE**
 [25.59] 650 **DF1320 QE**
 Clearance required for elemental removal

Size	660	1320
Weight (lbs.)	50.5	75.2

Dimensions shown are [inches] millimeters for general information and overall envelope size only. Weights listed include element. For complete dimensions please contact HYDAC to request a certified print.

Sizing Information

Total pressure loss through the filter is as follows:

Assembly $\Delta P = \text{Housing } \Delta P + \text{Element } \Delta P$

Housing Curve:

Pressure loss through housing is as follows:

Housing $\Delta P = \text{Housing Curve } \Delta P \times \frac{\text{Actual Specific Gravity}}{0.86}$

Adjustments must be made for viscosity & specific gravity of the fluid to be used! (see "Sizing HYDAC Filter Assemblies" in Section B - Overview)

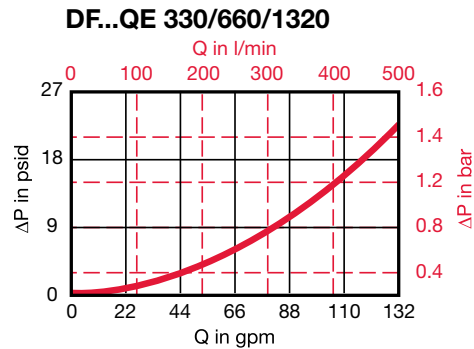
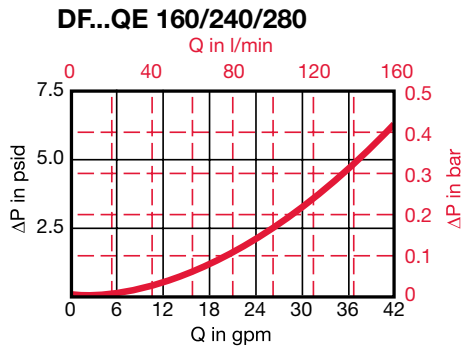
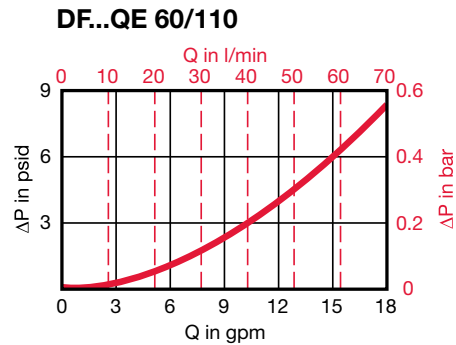
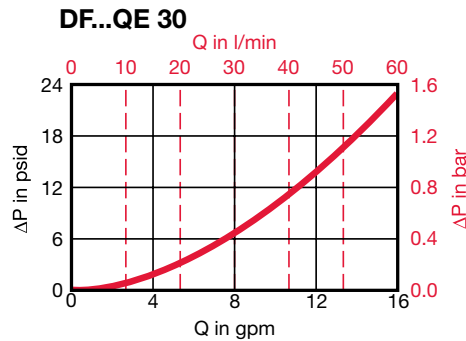

Element K Factors

$\Delta P \text{ Elements} = \text{Elements (K) Flow Factor} \times \text{Flow Rate (gpm)} \times \frac{\text{Actual Viscosity (SUS)}}{141 \text{ SUS}} \times \frac{\text{Actual Specific Gravity}}{0.86}$
(From Tables Below)

Optimicron	...D...ON Elements					
	1 μm	3 μm	5 μm	10 μm	15 μm	20 μm
0030 D XXX ON	4.27	3.507	2.376	1.251	0.768	0.62
0060 D XXX ON	2.936	1.427	1.004	0.664	0.537	0.347
0110 D XXX ON	1.416	0.735	0.527	0.333	0.254	0.164
0160 D XXX ON	1.015	0.604	0.423	0.225	0.204	0.175
0240 D XXX ON	0.631	0.379	0.293	0.175	0.134	0.115
0280 D XXX ON	0.304	0.185	0.15	0.082	0.075	0.064
0330 D XXX ON	0.452	0.23	0.185	0.135	0.085	0.067
0660 D XXX ON	0.207	0.106	0.086	0.051	0.039	0.031
1320 D XXX ON	0.102	0.053	0.042	0.025	0.019	0.015

Betamicon	...D...BH4HC Elements (High Collapse)			
	3 μm	5 μm	10 μm	20 μm
0030 D XXX BH4HC	5.005	2.782	1.992	1.043
0060 D XXX BH4HC	3.216	1.789	0.993	0.670
0110 D XXX BH4HC	1.394	0.818	0.489	0.307
0160 D XXX BH4HC	0.922	0.571	0.324	0.241
0240 D XXX BH4HC	0.582	0.373	0.214	0.159
0280 D XXX BH4HC	0.313	0.187	0.099	0.088
0330 D XXX BH4HC	0.423	0.247	0.154	0.110
0660 D XXX BH4HC	0.181	0.104	0.055	0.049
1320 D XXX BH4HC	0.088	0.055	0.033	0.022

Metal Fiber	...D...V Elements (High Collapse)			
	3 μm	5 μm	10 μm	20 μm
0030 D XXX V	1.011	0.740	0.411	0.200
0060 D XXX V	0.877	0.511	0.296	0.183
0110 D XXX V	0.452	0.304	0.182	0.118
0160 D XXX V	0.251	0.177	0.123	0.079
0240 D XXX V	0.169	0.137	0.093	0.062
0280 D XXX V	0.126	0.093	0.064	0.041
0330 D XXX V	0.121	0.097	0.065	0.043
0660 D XXX V	0.063	0.050	0.034	0.021
1320 D XXX V	0.032	0.026	0.018	0.012

Wire Mesh	...D...W/HC Elements (Low Collapse)			
	25, 50, 100, 200 μm			
0030 D XXX W/HC	0.166			
0060 D XXX W/HC	0.042			
0110 D XXX W/HC	0.023			
0160 D XXX W/HC	0.016			
0240 D XXX W/HC	0.010			
0280 D XXX W/HC	0.005			
0330 D XXX W/HC	0.008			
0660 D XXX W/HC	0.004			
1320 D XXX W/HC	0.002			

All Element K Factors in psi / gpm.