

LOW PRESSURE FILTERS

RFLD Welded Series

Inline Duplex Filters

230 psi • up to 3900 gpm

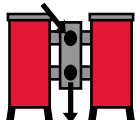

Hydraulic Symbol

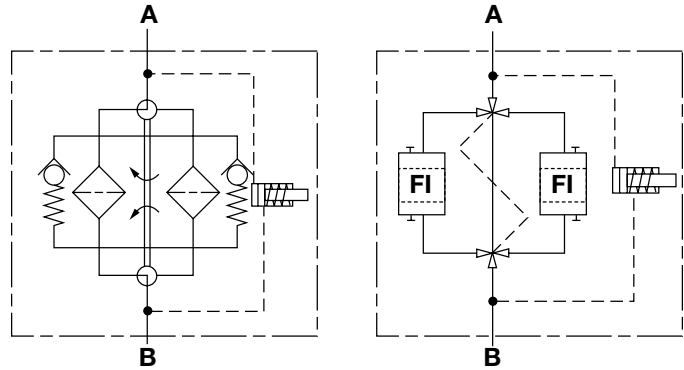

Features

- Models 1300 to 15020 are made of steel housings with bolt-on steel lids; Stainless steel models are available.
- ANSI flange connections for each filter size provide maximum connection flexibility eliminating additional adapters and intermediate flanges.
- Inlet and outlet connections are located on the same side of the transfer valve.
- Transfer valve and pressure equalization line allow easy changeover between filter housings without costly system shutdown.
- Models 5200 to 15020 use the same filter element size (1300 R) allowing maximum standardization in multiple filter element housings.
- Clogging indicators have no external dynamic seal. High reliability is achieved and magnetic actuation eliminates a leak point.

Notes: This filter is configured with anR..... type (return/low pressure) element, so if the filter requires a bypass, the bypass is located in the closed end cap of the cartridge element.

Most states and local jurisdictions in the United States require pressure vessels to be ASME stamped. It is the responsibility of the end customer to research and fully understand the ASME code requirements of the jurisdiction this filter will ultimately be installed in, and to fully communicate these requirements to HYDAC.

Technical Specifications

Mounting Method	Floor mounted legs <i>(Filters must not be used as pipe support)</i>
Port Connection	Inlet / Outlet - Transfer Valves <i>See chart below for details</i>
Flow Direction	Inlet: Front top Outlet: Front Bottom
Construction Materials	
Head, Lid	Steel
Note: Please inquire to the factory for available stainless steel models.	
Flow Capacity	
1300/1320	350 gpm (1300 lpm)
2500/2520	650 gpm (2500 lpm)
4000/4020	1050 gpm (4000 lpm)
5200/5220	1400 gpm (5200 lpm)
6500/6520	1700 gpm (6500 lpm)
7800/7820	2050 gpm (7800 lpm)
15000/15020	3900 gpm (15000 lpm)
Housing Pressure Rating	
Max. Allowable Working Pressure	150 psi (10 bar) <i>(standard)</i> 232 psi (16 bar) <i>(optional)</i>
Fatigue Pressure	Contact HYDAC
Burst Pressure	Contact HYDAC
Element Collapse Pressure Rating	
ON, W/HC	290 psid (20 bar)
ECON2, BN4AM, AM, P/HC	145 psid (10 bar)
Fluid Temperature Range 14°F to 212°F (-10°C to 100°C)	
Consult HYDAC for applications below 14°F (-10°C)	
Fluid Compatibility	
Compatible with all hydrocarbon based, synthetic, water glycol, oil/water emulsion, and high water based fluids when the appropriate seals are selected.	
Indicator Trip Pressure	
$\Delta P = 29$ psid (2 bar) -10% <i>(standard)</i>	
$\Delta P = 72$ psid (5 bar) -10% <i>(standard)</i>	
Bypass Valve Cracking Pressure	
$\Delta P = 43$ psid (3 bar) +10%	
$\Delta P = 87$ psid (6 bar) +10%	

Applications



Automotive



Gearboxes



Industrial



Power Generation



Pulp & Paper



Shipbuilding



Steel / Heavy Industry

Port Connections

Filter	Ball Valve				Segment / Butterfly Valve
	ANSI	SAE DN	DIN DN	SAE/DIN DN	DN
Size					
1300	2"	50	-	-	-
1320	3", 4"	-	125	80, 100	-
2500	3", 4"	-	125, 150	80, 100	150
2520	5", 6"	-	125, 150, 200	80, 100	150
4000/4020	4", 6", 8"	-	125, 150, 200	100	150, 200
5200/5220	4", 6", 8"	-	125, 150, 200	100	150, 200, 250
6500/6520	4", 6", 8"	-	125, 150, 200	100	150, 200, 250
7800/7820	4", 6", 8"	-	125, 150, 200	100	150, 200, 250
15000/15020	-	-	-	-	150, 200, 250

Model Code

RFLD ON 1300 C A T 3 A 1 . X / ZU 150 V DH

Filter Type _____

Element Media _____

ON = Optimicron® BN/AM = Betamicron®/Aquamicron®
 ECON2 = ECOmicron® AM = Aquamicron®
 W/HC = Wire Mesh P/HC = Polyester

Size _____

1300, 1320, 2500, 2520, 4000, 4020, 5200, 5220,
 6500, 6520, 7800, 7820, 15000, 15020

Operating Pressure _____

B = 150 psi (10 bar) C = 230 psi (16 bar)

Type of Change Over Valve _____

A = Ball Valve (one pc.)— ANSI 2", 3", 4", 6", 8" / DN 50, 80, 100, 125, 150, 200 (sz. 1300 - 2520)
 B = Segment Valve – ANSI 6", 8", 10", 12" / DN 150, 200, 250, 300 (sizes 2500 - 15020)
 C = Butterfly – ANSI (same as Segment sizes) / DN (same as Segment sizes) (sizes 2500 - 15020)
 E = Ball Valve (two pc.)— ANSI 8" / DN 200 (sizes 4000 - 15020)

Type of Connection _____

ANSI Flange Ports	DIN DN Ports
2 = 2" ANSI Flange (sizes 1300)	L = DN 50 (size 1300)
4 = 3" ANSI Flange (sizes 1300/2500)	S = SAE/DIN DN 80 (sizes 1300 - 2500)
5 = 4" ANSI Flange (sizes 1320 & 2500)	T = SAE/DIN DN 100 (sizes 1300 - 7820)
7 = 6" ANSI Flange (sizes 2520 - 7820)	U = DIN DN 125 (sizes 1320 - 7820)
8 = 8" ANSI Flange (sizes 2520 - 7820)	V = DIN DN 150 (sizes 2500 - 7820)
9 = 10" ANSI Flange (Consult HYDAC)	W = DIN DN 200 (sizes 4000 - 15020)
10 = 12" ANSI Flange (Consult HYDAC)	X = DIN DN 250 (sizes 5200 - 15020)
	Y = DIN DN 300 (sizes 5200 - 15020)

Filtration Rating (microns) _____

1, 3, 5, 10, 15, 20 = ON 3, 10 = BN4AM 3, 5, 10, 20 = ECON2
 40 = AM 25, 50, 100, 200 = W/HC 10, 20 = P/HC

Type of ΔP Clogging Indicator _____

A, B, BM, C, D (Others available upon request)

Type Code _____

1

Modification Number (latest version always supplied) _____

Country of Installation _____

(omit) = standard (non coded) ZU = ASME Coded with "ASME" Stamp

Flange _____

(omit) = DIN Flange Connection to DIN 2501/1 150 = 150 lbs ANSI Flange

Seals _____

(omit) = Nitrile rubber (NBR) (standard) V = Fluorocarbon elastomer (FKM)

Bypass Valve _____

(omit) = 43 psid (3 bar) (standard) B1 = 14.5 psid (1 bar) (lubrication or coolant applications)
 B6 = 87 psid (6 bar) (return line extended life)] not available with ECON2
 KB = No Bypass (flushing system)

Supplementary Details _____

(omit) = Cover Lifting Device (Handle only)
 DH = Cover Lifting Device (Davit lifting mechanism for sizes 4000 and larger, style may vary)
 W = Indicator with brass piston (for water base fluids)
 SO263 = Modification of elements for Skydrol or HYJET phosphate ester fluids
 L24, L48, L110, L220 = Lamp for D-type clogging indicator (LXX, XX = voltage)
 cRUus = Electrical Indicator with underwriter's recognition
 SFREE = Element specially designed to minimize electrostatic charge generation

Replacement Element Model Code

0850 R 010 ON / V B6

Size _____

0850, 1300, 1700, 2600

Filtration Rating (micron) _____

1, 3, 5, 10, 15, 20 = ON 3, 10 = BN4AM
 3, 5, 10, 20 = ECON2 40 = AM
 25, 50, 100, 200 = W/HC 10, 20 = P/HC

Element Media _____

ON, BN4AM, ECON2, AM, W/HC, P/HC

Seals _____

(omit) = Nitrile rubber (NBR) (standard)
 V = Fluorocarbon elastomer (FKM)

Bypass Valve _____

(omit) = 43 psid (3 bar) (standard)
 B1 = 14.5 psid (1 bar)
 B6 = 87 psid (6 bar)
 KB = No Bypass

Supplementary Details _____

W = (same as above)
 SO263 = (same as above)
 SFREE = (same as above)

Clogging Indicator Model Code

VM 2 B . X /

Indicator Prefix _____

VM = G 1/2 3000 psi

Trip Pressure _____

2 = 29 psid (2 bar) (standard)
 5 = 72 psid (5 bar) (optional)

Type of Indicator _____

A = No indicator, plugged port
 B = Pop-up indicator (auto reset)
 BM = Pop-up indicator (manual reset)
 C = electric switch - SPDT
 D = electric switch & LED light - SPDT

Modification Number _____

Supplementary Details _____

Seals _____

(omit) = Nitrile rubber (NBR) (standard)
 V = Fluorocarbon elastomer (FKM)

Light Voltage (D type indicators only) _____

L24 = 24V L110 = 110V

Thermal Lockout (VM, VD types C, D, J, and J4 only) _____

T100 = Lockout below 100°F

Underwriters Approval (VM, VD types C, D, J, and J4 only) _____

cRUus = Electrical Indicator with underwriter's recognition
 (For additional details and options, see Section H - Clogging Indicators.)

Model Codes Containing RED are non-stock items — Minimum quantities may apply — Contact HYDAC for information and availability

LOW PRESSURE FILTERS

Dimensions

RFLD 1300 / 1320

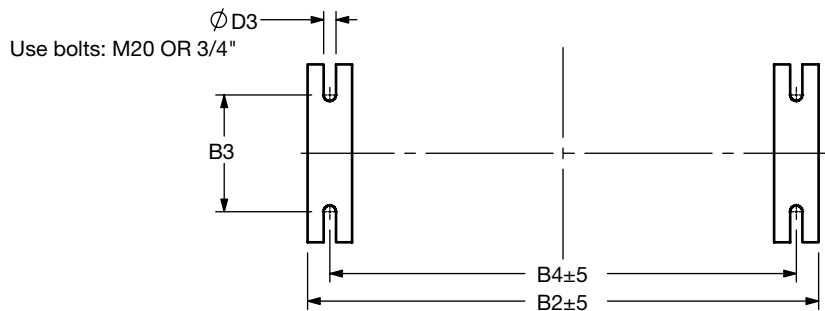
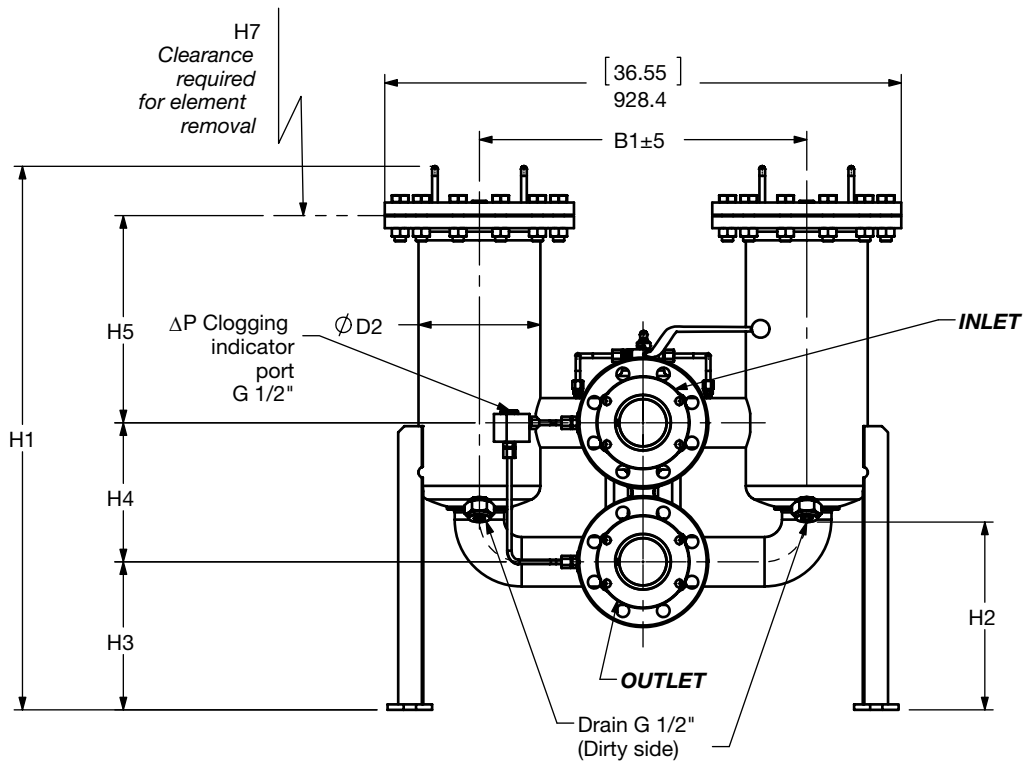
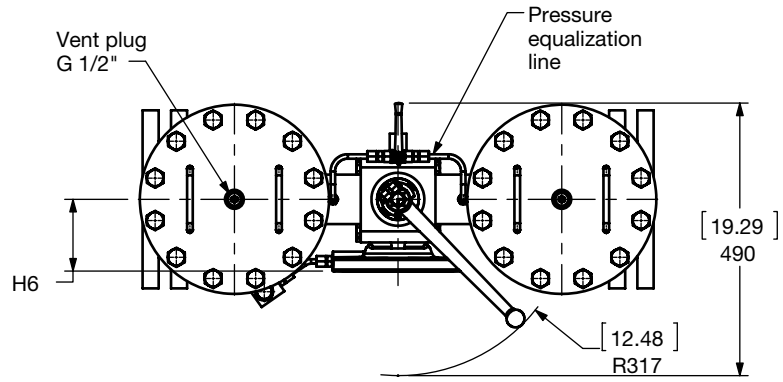

Foot Pattern

Size	1300	1320
Weight (lbs.)	330.7	460.8

Dimensions shown are [inches] millimeters for general information and overall envelope size only. Weights listed include element. For complete dimensions please contact HYDAC to request a certified print.

LOW PRESSURE FILTERS

Dimensions

RFLD 2500 / 2520

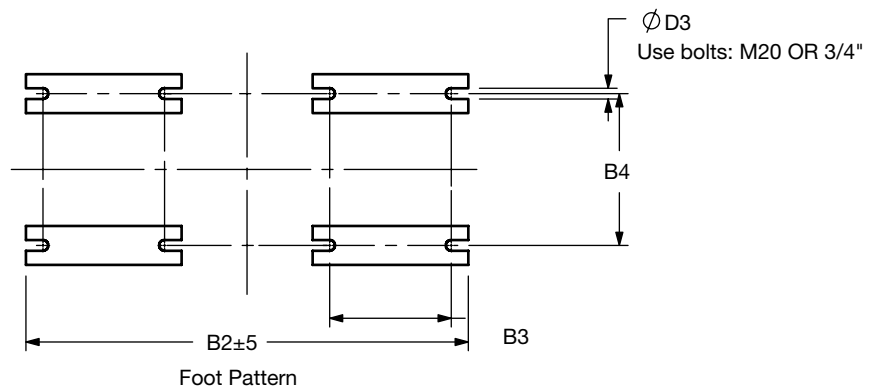
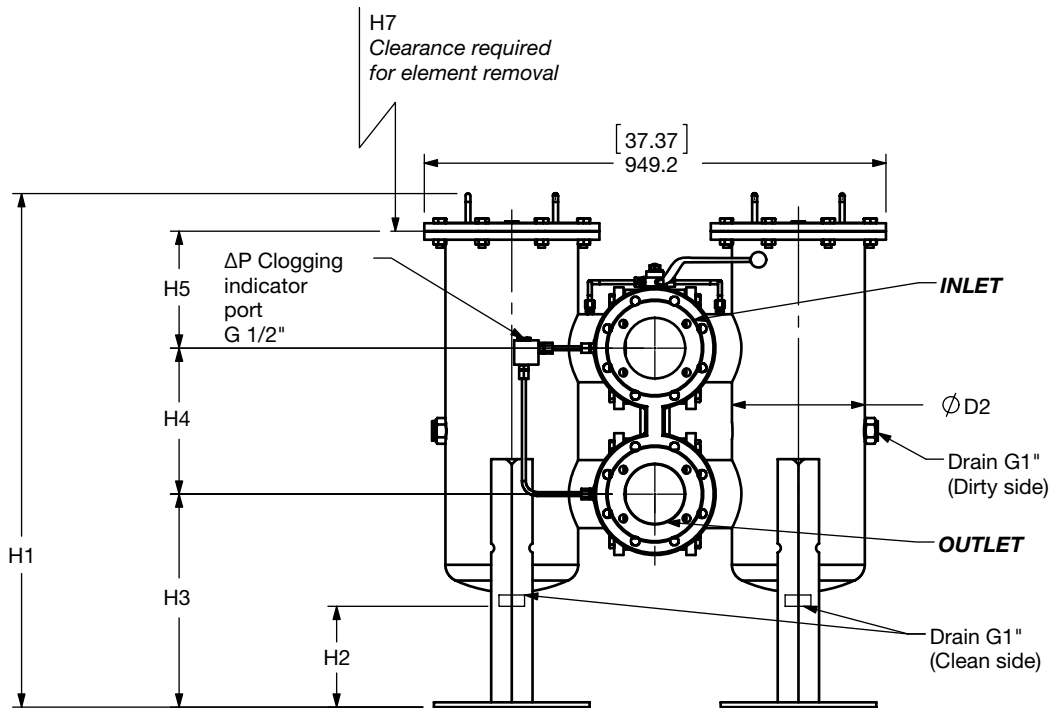
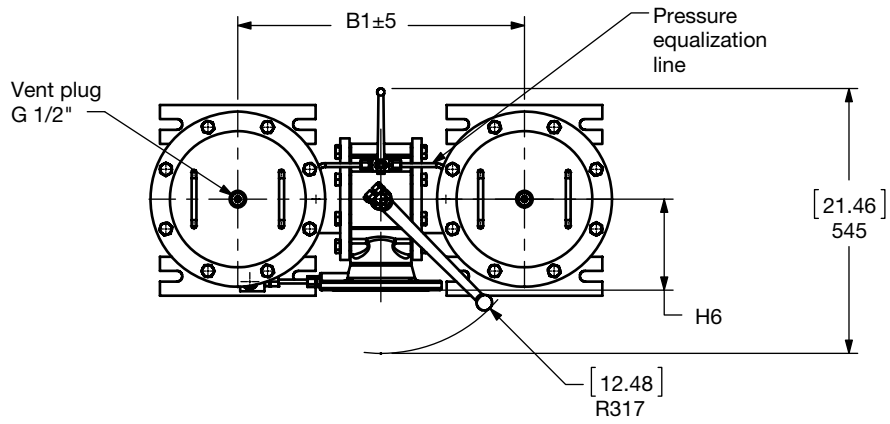

Size	2500	2520
Weight (lbs.)	632.8	721

Dimensions shown are [inches] millimeters for general information and overall envelope size only. Weights listed include element. For complete dimensions please contact HYDAC to request a certified print.

LOW PRESSURE FILTERS

Size	Flange Port	B1	B2	B3	B4	D2	D3	H1	H2	H3	H4	H5	H6	H7	Use Bolt
RFLD 2500	3" ANSI	(22.52) 572	(36.69) 932	(9.84) 250	(12.28) 312	(10.75) 273	(0.87) 22	(38.98) 990 (54.33) 1380	(8.66) 220	(16.06) 408	(9.06) 230	(11.00) 280 (26.38) 670	(4.72) 120	(16.78) 420 (31.89) 810	5/8" - 11 UNC HEAVY HEX
	4" ANSI	(23.15) 588	(37.32) 948	(9.84) 250	(12.28) 312	(10.75) 273	(0.87) 22	(38.98) 990 (54.33) 1380	(8.66) 220	(16.06) 408	(9.84) 250	(11.00) 280 (26.38) 670	(5.12) 130	(16.78) 420 (31.89) 810	5/8" - 11 UNC HEAVY HEX
RFLD 2500 / 2520	SAE / DIN DN 80	(21.57) 548	(35.75) 908	(9.84) 250	(12.28) 312	(10.75) 273	(0.87) 22	(38.98) 990 (54.33) 1380	(8.66) 220	(15.08) 383	(4.33) 110	(11.00) 280 (26.38) 670	(4.02) 102	(16.78) 420 (31.89) 810	M16 / M16
	SAE / DIN DN 100	(21.57) 548	(35.75) 908	(9.84) 250	(12.28) 312	(10.75) 273	(0.87) 22	(38.98) 990 (54.33) 1380	(8.66) 220	(15.08) 383	(9.06) 230	(10.24) 260 (25.59) 650	(6.57) 167	(16.78) 420 (31.89) 810	M16 / M20
	DIN DN 125	(22.52) 572	(36.69) 932	(9.84) 250	(12.28) 312	(10.75) 273	(0.87) 22	(41.34) 1050 (56.69) 1440	(8.66) 220	(16.06) 408	(9.06) 230	(10.24) 260 (25.59) 650	(4.72) 120	(16.78) 420 (31.89) 810	M16
	DIN DN 150	(23.15) 588	(37.32) 948	(9.84) 250	(12.28) 312	(10.75) 273	(0.87) 22	(41.34) 1050 (56.69) 1440	(8.66) 220	(16.06) 408	(9.84) 250	(9.44) 240 (24.80) 630	(5.12) 130	(16.78) 420 (31.89) 810	M20
	6" ANSI	(23.19) 589	(37.36) 949	(9.84) 250	(12.28) 312	(10.75) 273	(0.87) 22	(41.34) 1050 (56.69) 1440	(8.66) 220	(17.24) 438	(11.81) 300	(9.44) 240 (24.80) 630	(7.40) 188	(16.78) 420 (31.89) 810	3/4" - 10 UNC HEAVY HEX

Notes



LOW PRESSURE FILTERS

Dimensions
RFLD 4000 - 7820

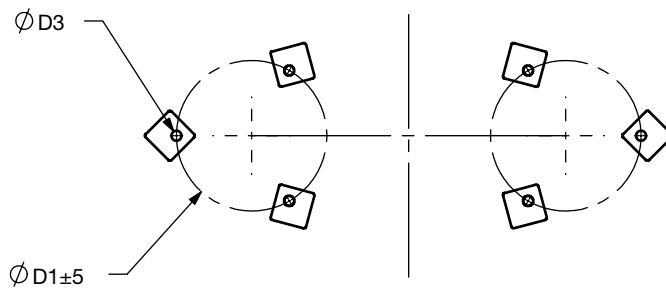
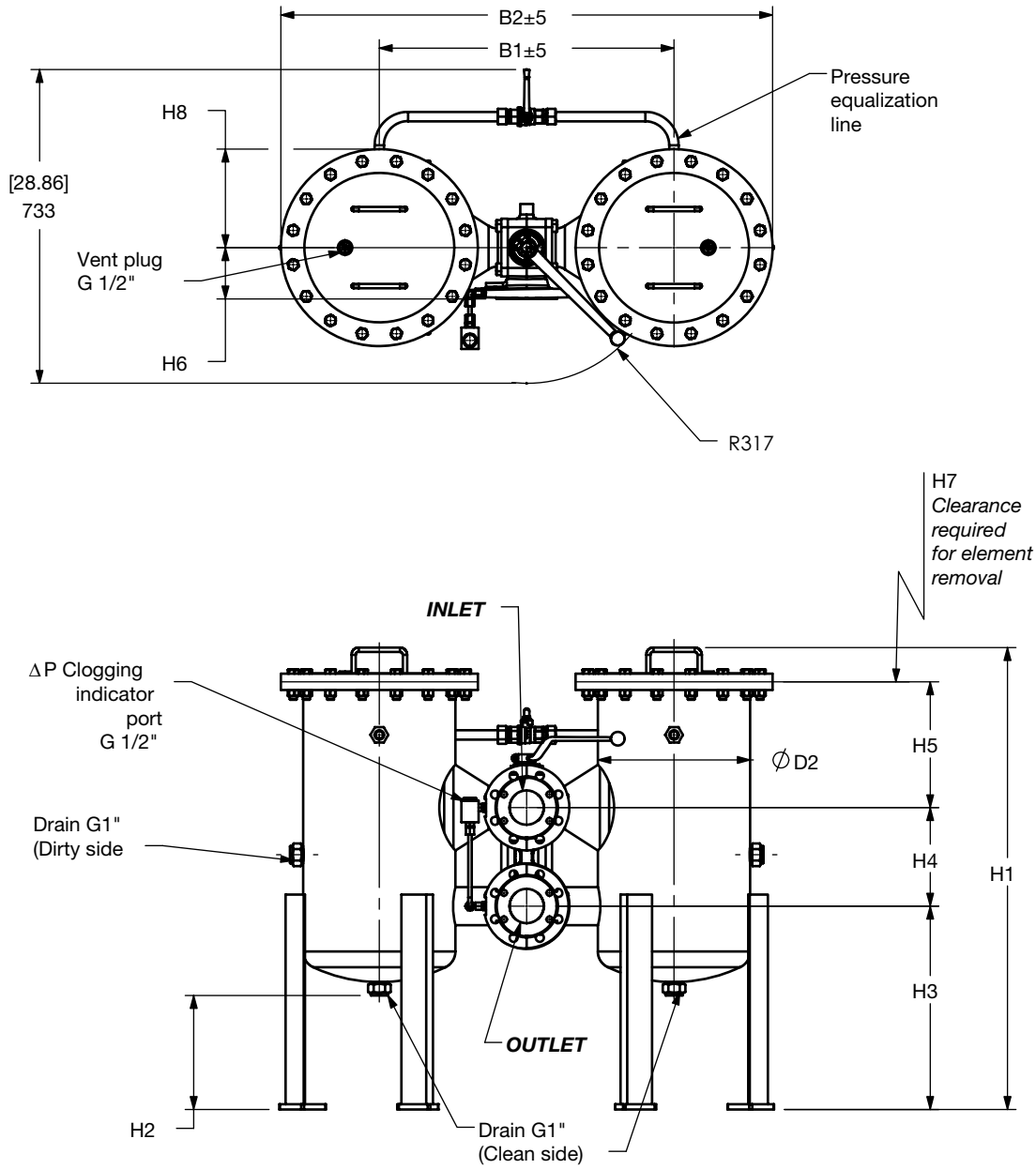

Foot Pattern

Size	4000	4020	5200	5220	6500	6520	7800	7820
Weight (lbs.)	866.5	1111.2	2107.7	2464.8	2471.4	2826.4	2489.1	2861.6

Dimensions shown are [inches] millimeters for general information and overall envelope size only. Weights listed include element. For complete dimensions please contact HYDAC to request a certified print.

LOW PRESSURE FILTERS

Size	Flange Port	B1	B2	D1	D2	D3	H1	H2	H3	H4	H5	H6	H7	H8	Use Bolts
RFLD 4000 / 4020	4" ANSI 150 LB	[27.72]	[45.83]	[12.99]	[14.02]	[0.87]	[42.52] 1080	[10.24]	[18.70]	[9.84]	[11.61] 295	[5.12]	[16.54] 420	[9.06]	5/8"-11 UNC Heavy Hex
	SAE / DIN DN 100	704	1164	330	356	22	[57.87] 1470	260	475	250	[26.97] 685	130	[31.89] 810	230	M16 - 4 Bolt Flange / M20 - Din Flange
	DIN DN 125	[28.46] 723	[46.57] 1183	[12.99] 330	[14.02] 356	[0.87] 22	[46.06] 1170 [61.42] 1560	[10.24] 260	[20.67] 525	[11.81] 300	[10.43] 265 [25.79] 655	[7.40] 188	[16.54] 420 [31.89] 810	[9.06] 230	M16
	DIN DN 150	[30.51]	[48.82]	[12.99]	[14.02]	[0.87]	[46.06] 1170	[10.24]	[20.67]	[11.81]	[10.43] 265	[7.48]	[16.54] 420	[9.06]	M20
	6" ANSI 150 LB	775	1240	330	356	22	[61.42] 1560	260	525	300	[25.79] 655	190	[31.89] 810	230	3/4"-10 UNC Heavy HEX
	DIN DN 200	[34.80]	[53.11]	[12.99]	[14.02]	[0.87]	[46.06] 1170	[10.24]	[20.67]	[19.69]	[2.56] 65	[10.63]	[16.54] 420	[9.06]	M20
	8" ANSI 150 LB	884	1349	330	356	22	[61.42] 1560	260	525	500	[13.98] 355	270	[31.89] 810	230	3/4"-10 UNC Heavy HEX
RFLD 5200 / 5220	4" ANSI 150 LB	[29.29]	[49.61]	[14.96]	[15.98]	[0.87]	[45.04] 1144	[9.84]	[18.31]	[9.84]	[13.82] 351	[5.12]	[19.69] 500	[10.04]	5/8"-11UNC HEAVY HEX
	SAE / DIN DN 100	744	1260	380	406	22	[62.36] 1584	250	465	250	[31.14] 791	130	[37.01] 940	255	M16 - 4 Bolt Flange / M20 - DIN Flange
	DIN DN 125	[30.04] 763	[50.19] 1275	[14.96] 380	[15.98] 406	[0.87] 22	[49.45] 1256 [66.77] 1696	[9.84] 250	[20.67] 525	[11.81] 300	[13.82] 351 [31.14] 791	[7.40] 188	[19.69] 500 [37.01] 940	[10.04] 255	M16
	DIN DN 150	[32.09]	[52.36]	[14.96]	[15.98]	[0.87]	[49.45] 1256	[9.84]	[20.67]	[11.81]	[13.82] 351	[7.48]	[19.69] 500	[10.04]	M20
	6" ANSI 150 LB	815	1330	380	406	22	[66.77] 1696	250	525	300	[31.14] 791	190	[37.01] 940	255	3/4"-10 UNC Heavy HEX
	DIN DN 200	[36.38]	[56.61]	[14.96]	[15.98]	[0.87]	[55.63] 1413	[9.84]	[20.67]	[19.69]	[5.94] 151	[10.63]	[19.69] 500	[10.04]	M20
	8" ANSI 150 LB	924	1438	380	406	22	[72.95] 1853	250	525	500	[23.27] 591	270	[37.01] 940	255	3/4"-10 UNC Heavy HEX
RFLD 6500 / 6520	4" ANSI 150 LB	[40.31]	[64.72]	[18.89]	[20.00]	[0.87]	[49.61] 1260	[10.24]	[21.26]	[9.84]	[15.35] 390	[5.12]	[19.69] 500	[12.20]	5/8"-11 UNC Heavy HEX
	SAE / DIN DN 100	1024	1644	480	508	22	[66.93] 1700	260	540	250	[32.68] 830	130	[37.01] 940	310	M16 - 4 Bolt Flange / M20 - DIN Flange
	DIN DN 125	[33.98] 863	[58.39] 1483	[18.89] 480	[20.00] 508	[0.87] 22	[49.61] 1260 [66.93] 1700	[10.24] 260	[21.26] 540	[11.81] 300	[13.39] 340 [30.71] 780	[7.40] 188	[19.69] 500 [37.01] 940	[12.20] 310	M16
	DIN DN 150	[36.02]	[60.43]	[18.89]	[20.00]	[0.87]	[49.61] 1260	[10.24]	[21.26]	[11.81]	[13.39] 340	[7.48]	[19.69] 500	[12.20]	M20
	6" ANSI 150 LB	915	1535	480	508	22	[66.93] 1700	260	540	300	[30.71] 780	190	[37.01] 940	310	3/4"-10 UNC Heavy HEX
	DIN DN 200	[40.31]	[64.72]	[18.89]	[20.00]	[0.87]	[55.63] 1413	[10.43]	[23.62]	[19.69]	[9.06] 230	[10.63]	[19.69] 500	[12.20]	M20
	8" ANSI 150 LB	1024	1644	480	508	22	[72.95] 1853	265	600	500	[26.38] 670	270	[37.01] 940	310	3/4"-10 UNC Heavy HEX
RFLD 7800 / 7820	4" ANSI 150 LB	[40.31]	[64.72]	[18.89]	[20.00]	[0.87]	[49.61] 1260	[10.24]	[21.26]	[9.84]	[15.35] 390	[5.12]	[19.69] 500	[12.20]	3/4"-10 UNC Heavy HEX
	SAE / DIN DN 100	1024	1644	480	508	22	[66.93] 1700	260	540	250	[32.68] 830	130	[37.01] 940	310	M16 - 4 Bolt Flange / M20 - DIN Flange
	DIN DN 125	[33.98] 863	[58.39] 1483	[18.89] 480	[20.00] 508	[0.87] 22	[49.61] 1260 [66.93] 1700	[10.24] 260	[21.26] 540	[11.81] 300	[13.39] 340 [30.71] 780	[7.40] 188	[19.69] 500 [37.01] 940	[12.20] 310	M16
	DIN DN 150	[36.02]	[60.43]	[18.89]	[20.00]	[0.87]	[49.61] 1260	[10.24]	[21.26]	[11.81]	[13.39] 340	[7.48]	[19.69] 500	[12.20]	M20
	6" ANSI 150 LB	915	1535	480	508	22	[66.93] 1700	260	540	300	[30.71] 780	190	[37.01] 940	310	5/8"-11 UNC Heavy HEX
	DIN DN 200	[40.31]	[64.72]	[18.89]	[19.69]	[0.87]	[55.63] 1413	[10.43]	[23.62]	[19.69]	[13.39] 340	[10.63]	[19.69] 500	[12.20]	M20
	8" ANSI 150 LB	1024	1644	480	500	22	[72.95] 1853	265	600	500	[30.71] 780	270	[37.01] 940	310	3/4"-10 UNC Heavy HEX

LOW PRESSURE FILTERS

Dimensions

RFLD 250X - 1502X Butterfly Version

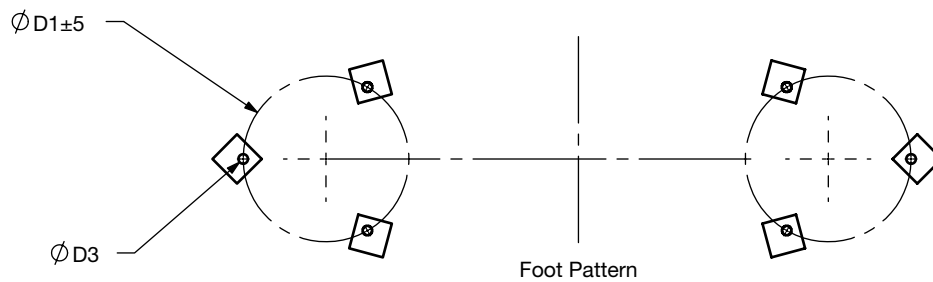
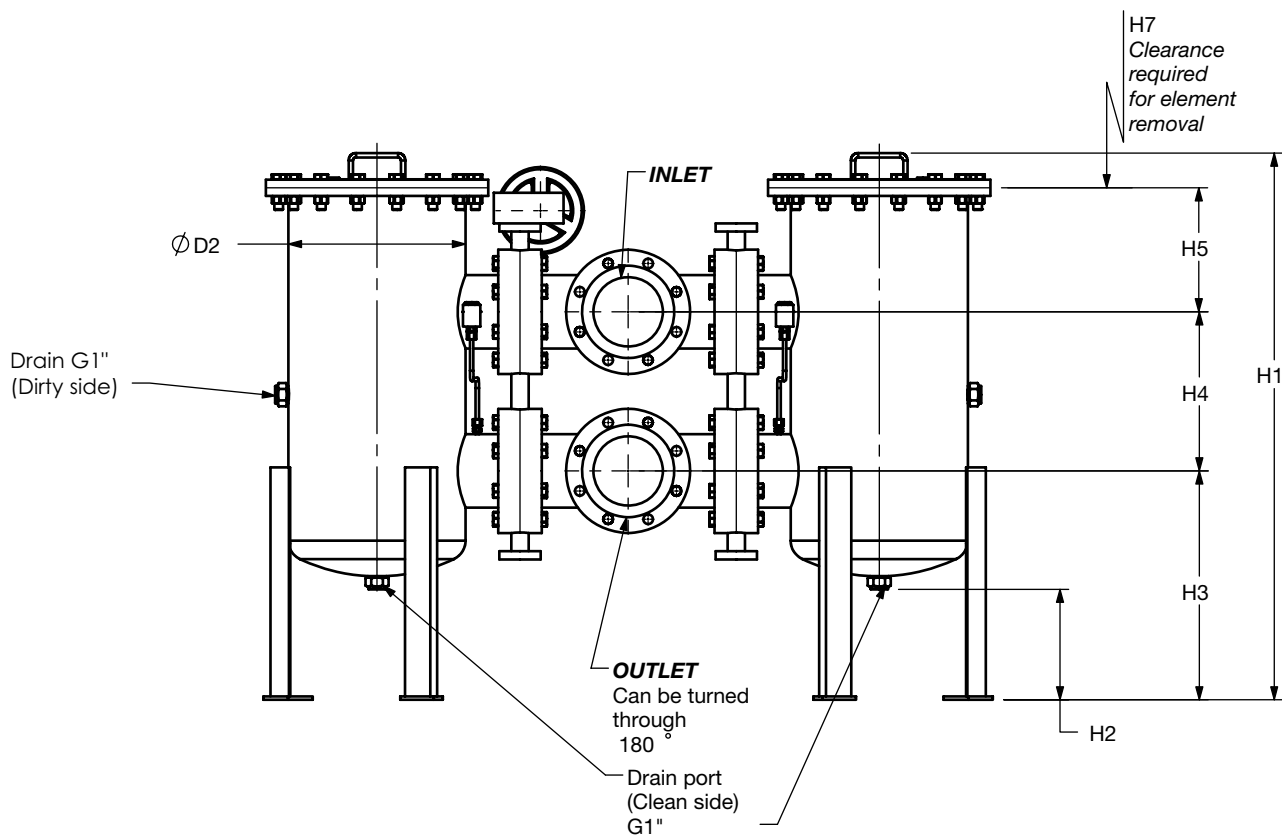
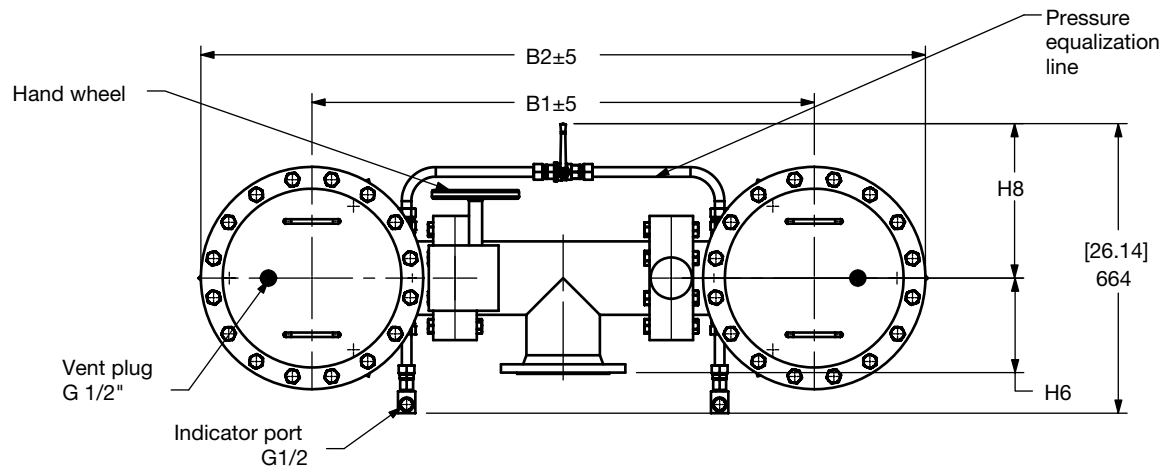

Size	2500	2520	4000	4020	5200	5220	6500	6520	7800	7820	15000	15020
Weight (lbs.)	632.8	721	866.5	1111.2	2107.7	2464.8	2471.4	2826.4	2489.1	2861.6	3278.3	3578.2

Dimensions shown are [inches] millimeters for general information and overall envelope size only. Weights listed include element. For complete dimensions please contact HYDAC to request a certified print.

LOW PRESSURE FILTERS

Size	Flange Port	B1	B2	D1	D2	D3	H1	H2	H3	H4	H5	H6	H7	H8
RFLD 2500 / 2520	DN 150	[40.08] 1018	[54.25] 1378	[12.99] 330	[10.75] 273	[0.87] 22	[43.62] 1108 [58.98] 1498	[8.66] 220	[18.11] 460	[14.37] 365	[8.31] 211 [23.66] 601	[8.66] 220	[16.54] 420 [31.89] 810	[12.99] 330
RFLD 4000 / 4020	DN 150	[45.35] 1152	[63.62] 1616	[12.99] 330	[14.02] 356	[0.87] 22	[46.06] 1170 [61.42] 1560	[10.24] 260	[20.67] 525	[14.37] 365	[7.87] 200 [23.23] 590	[8.66] 220	[16.54] 420 [31.89] 810	[13.78] 350
	DN 200	[48.82] 1240	[67.87] 1724	[12.99] 330	[14.02] 356	[0.87] 22	[47.44] 1205 [62.79] 1595	[9.84] 250	[20.67] 525	[14.37] 365	[9.25] 235 [24.61] 625	[10.24] 260	[19.69] 500 [37.01] 940	[14.57] 370
RFLD 5200 / 5220	DN 150	[45.35] 1152	[65.59] 1666	[14.96] 380	[15.98] 406	[0.87] 22	[6.14] 156 [66.77] 1696	[9.84] 250	[20.67] 525	[14.37] 365	[11.26] 286 [28.58] 726	[8.66] 220	[19.69] 500 [37.01] 940	[13.78] 350
	DN 200	[50.39] 1280	[70.63] 1794	[14.96] 380	[15.98] 406	[0.87] 22	[49.45] 1256 [66.77] 1696	[9.84] 250	[20.67] 525	[14.37] 365	[11.26] 286 [28.58] 726	[10.24] 260	[19.69] 500 [37.01] 940	[14.57] 370
	DN 250	[58.89] 1496	[79.13] 2010	[14.96] 380	[15.98] 406	[0.87] 22	[52.20] 1326 [69.53] 1766	[10.24] 260	[22.05] 560	[17.72] 450	[9.29] 236 [26.61] 676	[13.78] 350	[19.69] 500 [37.01] 940	[15.75] 400
RFLD 6500 / 6520	DN 150	[50.87] 1292	[75.43] 1916	[18.89] 480	[20.00] 508	[0.87] 22	[49.61] 1260 [66.93] 1700	[10.24] 260	[21.26] 540	[14.37] 365	[10.83] 275 [28.15] 715	[8.66] 220	[19.69] 500 [37.01] 940	[13.78] 350
	DN 200	[54.33] 1380	[78.89] 2004	[18.89] 480	[20.00] 508	[0.87] 22	[54.33] 1380 [71.65] 1820	[10.24] 260	[23.62] 600	[14.37] 365	[13.19] 335 [30.51] 775	[10.24] 260	[19.69] 500 [37.01] 940	[14.57] 370
	DN 250	[62.44] 1586	[87.01] 2210	[18.89] 480	[20.00] 508	[0.87] 22	[54.33] 1380 [71.65] 1820	[10.24] 260	[23.62] 600	[17.72] 450	[9.84] 250 [27.17] 690	[13.78] 350	[19.69] 500 [37.01] 940	[15.75] 400
RFLD 7800 / 7820	DN 150	[50.87] 1292	[75.43] 1916	[18.89] 480	[20.00] 508	[0.87] 22	[49.61] 1260 [66.93] 1700	[10.24] 260	[21.26] 540	[14.37] 365	[10.83] 275 [28.15] 715	[8.66] 220	[19.69] 500 [37.01] 940	[13.78] 350
	DN 200	[54.33] 1380	[78.89] 2004	[18.89] 480	[20.00] 508	[0.87] 22	[54.33] 1380 [71.65] 1820	[10.24] 260	[23.62] 600	[14.37] 365	[13.19] 335 [30.51] 775	[10.24] 260	[19.69] 500 [37.01] 940	[14.57] 370
	DN 250	[62.44] 1586	[87.01] 2210	[18.89] 480	[20.00] 508	[0.87] 22	[54.33] 1380 [71.65] 1820	[10.24] 260	[23.62] 600	[17.72] 450	[9.84] 250 [27.17] 690	[13.78] 350	[19.69] 500 [37.01] 940	[15.75] 400
RFLD 15000 / 15020	DN 200	[63.78] 1620	[96.46] 2450	[27.17] 690	[27.99] 711	[0.87] 22	[56.10] 1425 [73.43] 1865	[10.24] 260	[25.79] 655	[14.37] 365	[12.99] 330 [30.31] 770	[10.24] 260	[19.69] 500 [37.01] 940	[14.57] 370
	DN 250	[71.50] 1816	[104.17]] 2646	[27.17] 690	[27.99] 711	[0.87] 22	[56.10] 1425 [73.43] 1865	[10.24] 260	[25.79] 655	[17.72] 450	[9.84] 250 [27.17] 690	[13.78] 350	[19.69] 500 [37.01] 940	[15.75] 400
	DN 300	[77.01] 1956	[109.69]] 2786	[27.17] 690	[27.99] 711	[0.87] 22	[59.06] 1500 [76.38] 1940	[10.24] 260	[26.38] 670	[20.28] 515	[9.25] 235 [26.57] 675	[15.75] 400	[19.69] 500 [37.01] 940	[16.93] 430

LOW PRESSURE FILTERS

Dimensions

RFLD 4000 - 15020 Segment Version

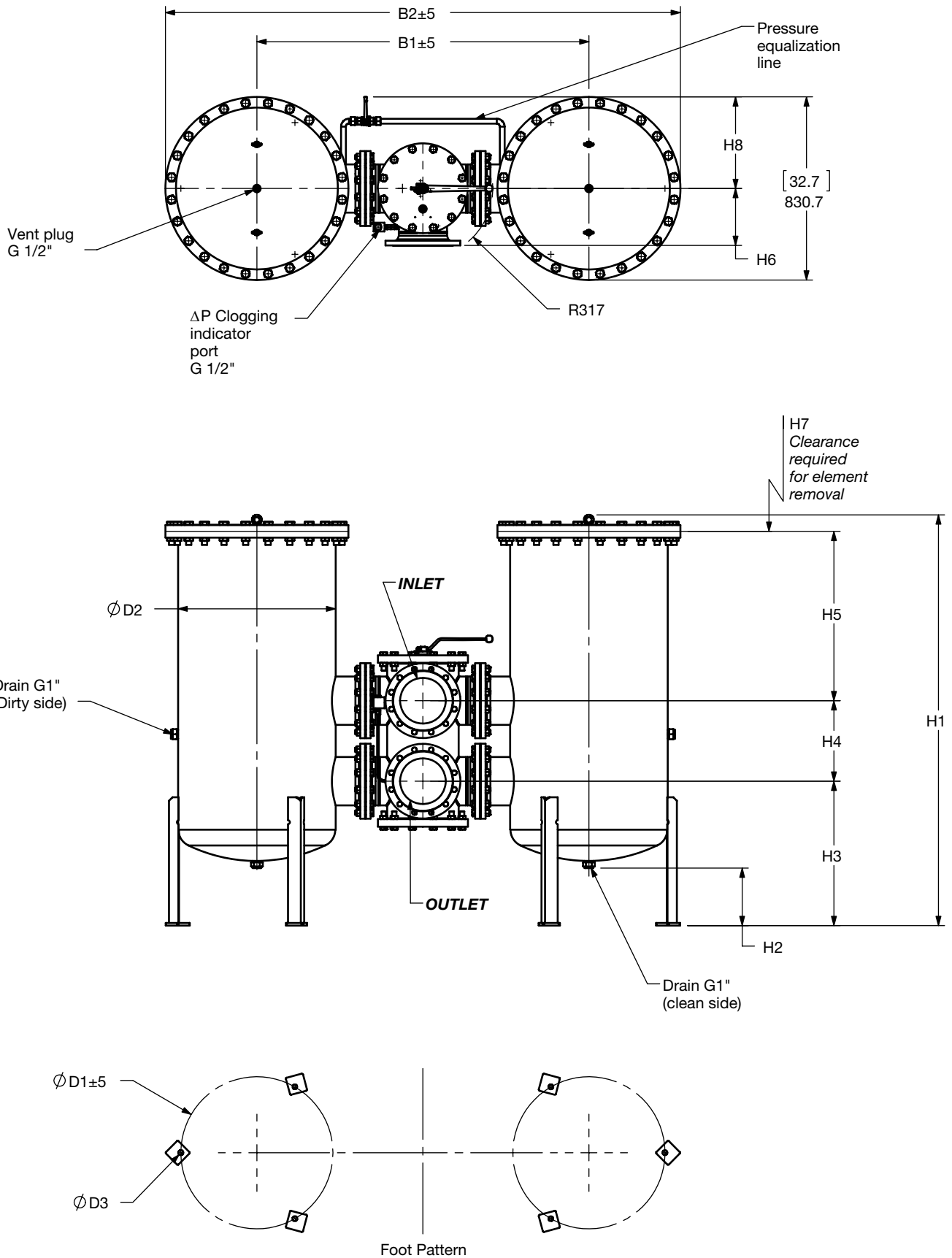

Size	4000	4020	5200	5220	6500	6520	7800	7820	15000	15020
Weight (lbs.)	866.5	1111.2	2107.7	2464.8	2471.4	2826.4	2489.1	2861.6	3278.3	3578.2

Dimensions shown are [inches] millimeters for general information and overall envelope size only. Weights listed include element. For complete dimensions please contact HYDAC to request a certified print.

LOW PRESSURE FILTERS

Size	Flange Port	B1	B2	D1	D2	D3	H1	H2	H3	H4	H5	H6	H7	H8	Use Bolts
RFLD 4000 / 4020	DN 200	[44.25] 1124	[62.59] 1590	[12.99] 330	[14.02] 356	[0.87] 22	[49.21] 1250 [62.79] 1595	[10.24] 260	[20.67] 525	[14.37] 365	[9.25] 235 [24.61] 625	[10.28] 261	[16.54] 420 [31.89] 810	[14.57] 370	M20
RFLD 5200 / 5200	DN 200	[45.91] 1166	[66.14] 1680	[14.96] 380	[15.98] 406	[0.87] 22	[49.80] 1265 [67.13] 1705	[9.84] 250	[20.67] 525	[14.37] 365	[11.26] 286 [28.58] 726	[10.28] 261	[19.69] 500 [37.01] 940	[14.57] 370	M20
	DN 250	[51.65] 1312	[71.85] 1825	[14.96] 380	[15.98] 406	[0.87] 22	[52.13] 1324 [69.45] 1764	[9.84] 250	[22.05] 560	[17.72] 450	[9.29] 236 [26.61] 676	[12.68] 322	[19.69] 500 [37.01] 940	[15.75] 400	M24
RFLD 6500 / 6520	DN 200	[49.84] 1266	[74.25] 1886	[18.89] 480	[20.00] 508	[0.87] 22	[54.33] 1380 [71.65] 1820	[10.24] 260	[23.62] 600	[14.37] 365	[13.19] 335 [30.51] 775	[10.28] 261	[19.69] 500 [37.01] 940	[14.57] 370	M20
	DN 250	[55.2] 1402	[79.61] 2022	[18.89] 480	[20.00] 508	[0.87] 22	[54.33] 1380 [71.65] 1820	[9.84] 250	[23.62] 600	[17.72] 450	[9.84] 250 [27.17] 690	[12.68] 322	[19.69] 500 [37.01] 940	[15.75] 400	M24
RFLD 7800 / 7820	DN 200	[49.84] 1266	[74.25] 1886	[18.89] 480	[20.00] 508	[0.87] 22	[54.33] 1380 [71.65] 1820	[10.24] 260	[23.62] 600	[14.37] 365	[13.19] 335 [30.51] 775	[10.28] 261	[19.69] 500 [37.01] 940	[14.57] 370	M20
	DN 250	[55.2] 1402	[79.61] 2022	[18.89] 480	[20.00] 508	[0.87] 22	[54.33] 1380 [71.65] 1820	[10.24] 260	[23.62] 600	[17.72] 450	[9.84] 250 [27.17] 690	[12.68] 322	[19.69] 500 [37.01] 940	[15.75] 400	M24
RFLD 15000 / 15020	DN 200	[59.29] 1506	[91.97] 2336	[27.17] 690	[27.99] 711	[0.87] 22	[56.10] 1425 [73.43] 1865	[10.35] 263	[25.79] 655	[14.37] 365	[12.99] 330 [30.31] 770	[10.28] 261	[19.69] 500 [37.01] 940	[16.34] 415	M20
	DN 250	[64.09] 1628	[96.77] 2458	[27.17] 690	[27.99] 711	[0.87] 22	[56.10] 1425 [73.43] 1865	[10.35] 263	[25.19] 640	[17.72] 450	[10.24] 260 [27.56] 700	[12.68] 322	[19.69] 500 [37.01] 940	[16.34] 415	M24

Notes



LOW PRESSURE FILTERS

Sizing Information

Total pressure loss through the filter is as follows:

$$\text{Assembly } \Delta P = \text{Housing } \Delta P + \text{Element } \Delta P$$

Housing Curve:

Pressure loss through housing is as follows:

$$\text{Housing } \Delta P = \text{Housing Curve } \Delta P \times \frac{\text{Actual Specific Gravity}}{0.86}$$

Adjustments must be made for viscosity & specific gravity of the fluid to be used! (see "Sizing HYDAC Filter Assemblies" in Section B - Overview)

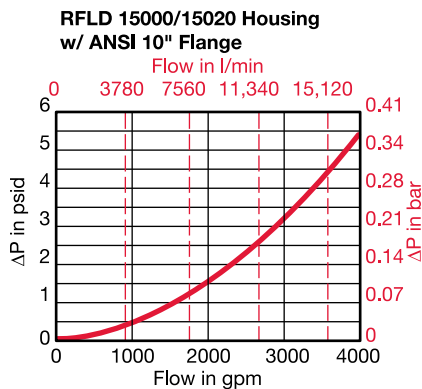
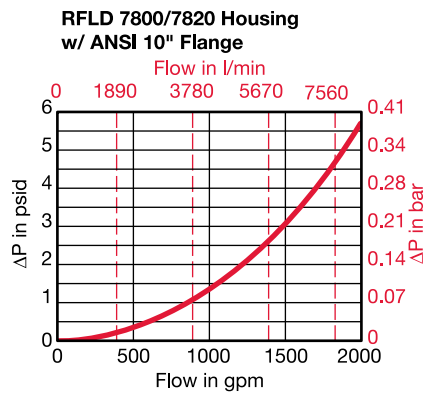
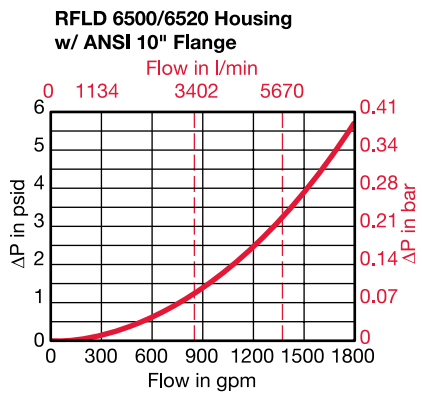
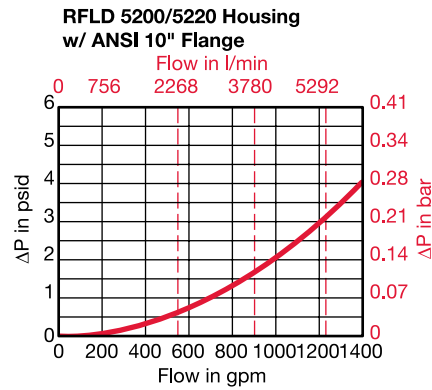
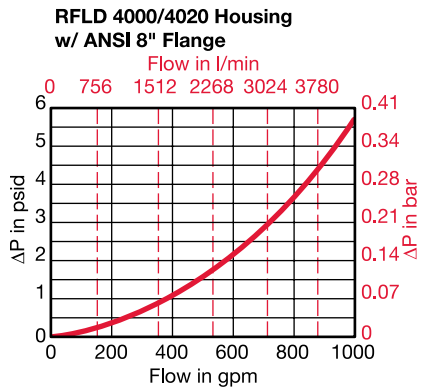
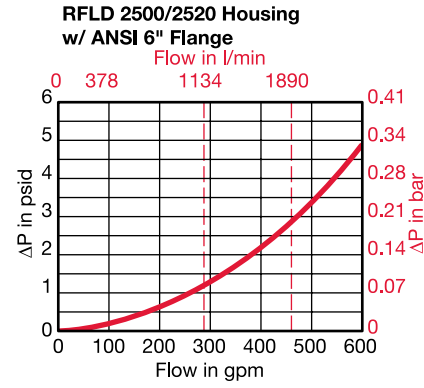
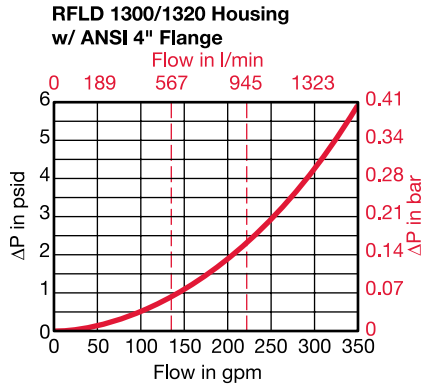

Required Element Per Housing

Housing Size	Element Size	Elements per Side
1300 / 1320	1300 / 2600	1 / 1
2500 / 2520	0850 / 1700	3 / 3
4000 / 4020	0850 / 1700	5 / 5
5200 / 5220	1300 / 2600	4 / 4
6500 / 6520	1300 / 2600	5 / 5
7800 / 7820	1300 / 2600	6 / 6
15000 / 15020	1300 / 2600	10 / 10

Element K Factors

$$\Delta P \text{ Elements} = \text{Elements (K) Flow Factor} \times \text{Flow Rate (gpm)} \times \frac{\text{Actual Viscosity (SUS)}}{141 \text{ SUS}} \times \frac{\text{Actual Specific Gravity}}{0.86}$$

(From Tables Below)

Optimicron Size	...R...ON					
	1 µm	3 µm	5 µm	10 µm	15 µm	20 µm
0850 R XXX ON	0.152	0.072	0.055	0.032	0.024	0.02
1300 R XXX ON	0.094	0.04	0.032	0.019	0.018	0.012
1700 R XXX ON	0.074	0.035	0.029	0.015	0.014	0.01
2600 R XXX ON	0.046	0.02	0.016	0.01	0.009	0.006

ECOMICRON Size	...R...ECON2			
	3 µm	5 µm	10 µm	20 µm
0850 R XXX ECON2	0.082	0.055	0.038	0.022
1300 R XXX ECON2	0.044	0.033	0.022	0.016
1700 R XXX ECON2	0.038	0.027	0.016	0.011
2600 R XXX ECON2	0.022	0.016	0.011	0.005

Betamicron/Aquamicron Size	...R...BN4AM	
	3 µm	10 µm
0850 R XXX BN4AM	0.154	0.049
1300 R XXX BN4AM	0.088	0.033
1700 R XXX BN4AM	0.071	0.027
2600 R XXX BN4AM	0.055	0.016

Aquamicron Size	...R...AM
	40 µm
0850 R 040 AM	0.040
1300 R 040 AM	0.026
1700 R 040 AM	0.020
2600 R 040 AM	0.013

Wire Mesh Size	...R...W/HC
	25, 50, 100, 200 µm
0850 R XXX W/HC	0.003
1300 R XXX W/HC	0.002
1700 R XXX W/HC	0.001
2600 R XXX W/HC	0.001

Polyester Size	...R...P/HC	
	10 µm	20 µm
0850 R XXX P/HC	0.007	0.003
1300 R XXX P/HC	0.004	0.002
1700 R XXX P/HC	0.003	0.002
2600 R XXX P/HC	0.002	0.001

All Element K Factors in psi / gpm.