

LOW PRESSURE FILTERS

RFM Series

In-Tank Return Line Filters

145 psi • up to 224 gpm

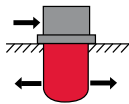

Features

- The compact and lightweight design make RFM filters especially suitable for mobile applications.
- RFM filters are constructed of polyamide plastic housing and lid.
- RFM 90/150/210/270 drop in replacement for "Tank Topper" filters.
- Sizes 50 - 851 aluminum alloy is water tolerant - anodization is not required for water based fluids (HWBF).
- The filter bowl on models 50 - 270 also serves as a contamination basket - removed to change element.
- Models 330, 500, 661, and 851 have filter elements equipped with separate, reusable contamination baskets.
- Sizes 75/90/150/165/185 available with 4- or 2-bolt tank flange.
- Second inlet optional port available for sizes 75, 165, 185 only with 4-bolt mounting head.
- Sizes 975 & 1100 added for increased flow capacities
- Sizes 50, 975 and 1100 utilize separate bypass assemblies
- Size 50 only available with BN4HC elements

Note: This filter is configured with anR..... type (return/low pressure) element, so if the filter requires a bypass, the bypass is located in the closed end cap of the cartridge element. (Exception - sizes 50, 975, 1100)

Consult HYDAC for applications using RFM50. RFM50 is not a standard offering.

Applications



Agricultural



Automotive



Construction

Hydraulic Symbol

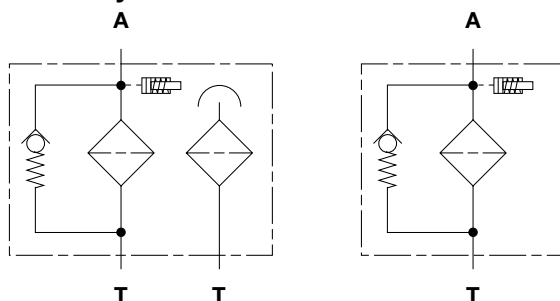

Technical Specifications

Mounting Method			
75/90/150/165/185	2 mounting holes - filter housing		
50/75/90/150/165/185/210/270/ 330/500/661/851/975/1100	4 mounting holes - filter housing		
Port Connections	Inlet / Outlet		
50	SAE-8 / 0.9"		
90/150	SAE-12 / 1"		
75/165/185	SAE-16 / 1.26" Smooth Port		
210/270	SAE-20 / Open Bottom		
330/500	SAE-24 / 2" NPT		
	1 1/2" SAE Flange, Code 61 / 2" NPT		
661/851	2 1/2" SAE Flange, Code 61 / G 2		
975/1100	1/2" BSPP		
	2" SAE Straight Thread / 2" NPT		
	2 1/2" NPT Threaded / 2" NPT M		
	2 1/2" SAE Code 61 Flange / 2" NPT M		
Direction of Flow	Side inlet and bottom outlet.		
Mat. of Construc.	Head	Bowl	Lid
50/90/150/75/165/185	Aluminum	Polyamide	Polyamide
210/270	Aluminum	Steel	Polyamide
330/500/661/851	Aluminum	Polyamide	Aluminum
975/1100	Aluminum	Steel	Steel
Flow Capacity			
50 - 13 gpm (50 lpm)	270 - 71 gpm (270 lpm)		
75 - 20 gpm (75 lpm)	330 - 87 gpm (330 lpm)		
90 - 24 gpm (90 lpm)	500 - 132 gpm (500 lpm)		
150 - 40 gpm (150 lpm)	661 - 174 gpm (660 lpm)		
165 - 43 gpm (165 lpm)	851 - 225 gpm (850 lpm)		
185 - 49 gpm (185 lpm)	975 - 258 gpm (950 lpm)		
210 - 55 gpm (210 lpm)	1100 - 300 gpm (1100 lpm)		
Housing Pressure Rating			
Max. Allowable Working Pressure*	145 psi (10 bar), 101.5 psi (7 bar) (Sizes 975 & 1100)		
Fatigue Pressure	145 psi (10 bar) @ 1 million cycles		
Burst Pressure	75-500 >580 psi (40 bar)		
	50, 661/851	536 psi (37 bar)	
	975/1100	Consult Factory	
Element Collapse Pressure Rating			
BN4HC (size 50, 975 & 1100 only)	145 psid (10 bar)		
ON (size 50-851 only), W/HC	290 psid (20 bar)		
ECON2, BN4AM, AM, P/HC, MM	145 psid (10 bar)		
V	435 psid (30 bar)		
Fluid Temperature Range	-22°F to 212°F (-30°C to 100°C)		
Consult HYDAC for applications below -22°F (-30°C)			
Fluid Compatibility	Compatible with all hydrocarbon based, synthetic, water glycol, oil/water emulsion, and high water based fluids when the appropriate seals are selected.		
Indicator Trip Pressure			
P = 20 psi (1.4 bar) - 10%			
P = 29 psi (2 bar) -10% (standard)			
P = 72 psi (5 bar) -10% (optional)			
Bypass Valve Cracking Pressure			
ΔP = 43 psid (3 bar) +10% (Standard - All sizes except 50, 975, 1100)			
ΔP = 87 psid (6 bar) +10% (Optional - Sizes 50, 975 & 1100 not available)			
ΔP = 25 psid (1.7 bar) +10% (Standard for Sizes 50, 975 & 1100)			

*Note: All RFM Filters MAWP reduce to 7 bar (101.5 psi) when using the following "VMF" and "VR" indicators: B, BM, E, ES, GC, LE, LZ.

Model Code

RFM ON 330 B F F 3 D 1 . X / 12 - V - - L24

Filter Type _____
RFM = In-Tank Return Line Filter

Element Media _____
ON = Optimicron® BN/HC = Betamicon® (Sizes 50, 975, 1100 only)
BN/AM = Betamicon®/Aquamicron® (Sizes 330 to 851 only)
ECON2 = ECOmicron® (Not for sizes 50, 75, 210, 270)
AM = Aquamicron® (Sizes 330 to 851 only)
W/HC = Wire Mesh (Sizes 75 to 851) P/HC = Polyester (Sizes 330 to 851 only)
MM = Mobilemicron® (Sizes 75 to 851)

Size _____
50, 75, 90, 150, 165, 185, 210, 270, 330, 500, 661, 851, 975, 1100

Working Pressure _____
B = 145 psi (10 bar) V = 101.5 psi (7 bar) (975 & 1100 Standard* - Note previous page)

Optional Second Inlet Connection _____
(omit) = no second port M = 2 1/2" SAE Flange Code 61 (sz. 661, 851, 975 & 1100 only)
D = 1" Threaded (SAE-16) (sz. 75, 165, 185) N = 2 1/2" NPT Threads (sz. 975, 1100 only)
F = 1 1/2" Threaded (SAE-24) (sz. 330, 500 only) V = 2 x 1" (SAE-16) (sz. 210, 270 only)
G = 2" Threaded Port (sz. 975, 1100 only)
K = 1 1/2" SAE Flange Code 61 (sz. 330, 500 only)

Inlet Connection/Port Size (1 Inlet) _____
B = 1/2" Threaded (SAE-8) (sz. 50 only) N = 2 1/2" NPT Threads (sz. 975, 1100 only)
C = 3/4" Threaded (SAE-12) (sz. 90, 150 only) Z = Customer Specific
D = 1" Threaded (SAE-16) (sz. 75, 165 & 185 only)
E = 1 1/4" Threaded (SAE-20) (sz. 210, 270 only)
F = 1 1/2" Threaded (SAE-24) (sz. 210, 270, 330, & 500 only)
G = 2" Threaded Port (sz. 975 & 1100 only)
K = 1 1/2" SAE Flange Code 61 (sz. 330, 500 only)
M = 2 1/2" SAE Flange Code 61 (sz. 661, 851, 975 & 1100 only)

Filtration Rating (microns) _____
1, 3, 5, 10, 15, 20 = ON 3, 5, 10, 20 = BN/HC 3, 10 = BN/AM 3, 5, 10, 20 = ECON2
40 = AM 25, 50, 100, 200 = W/HC 10, 20 = P/HC 10, 15 = MM

Type of Static Clogging Indicator _____
A, B, BM, C, D, E, F, FD (Others available upon request)

Type Number _____
0 = no indicator, no ports 1-3 = clogging indicator positions (see chart)

Modification Number (latest version always supplied) _____

Inlet Port Configuration _____
0 = BSPP Straight Thread Ports 3 = NPT Ports (sizes 975, 1100 only)
12 = SAE Straight Thread O-Ring Boss Ports (sz. 50-500, 975, 1100) 16 = SAE Flange Code 61 (sz. 330-851, 975, 1100)

Seals _____
(omit) = Nitrile rubber (NBR) (standard) V = Fluorocarbon elastomer (FKM) EPR = Ethylene propylene rubber (EPR)

Bypass Valve _____
(omit) = 43 psid (3 bar) (standard) B1.7 = 25 psid (1.7 bar) (50, 975 & 1100 only setting available for bypass)
B1 = 14.5 psid (1 bar) lube or coolant B6 = 87 psid (6 bar) (return line extended life) KB = no bypass (flushing systems)] not available with ECON2

Supplementary Details

- SO263 = Modification of elements for Skydrol or HYJET phosphate ester fluids
- L24, L48, L110, L220 = Lamp for D-type clogging indicator (LXX, XX = voltage)
- SO150H = Anodized for high water based fluids, phosphate esters and skydrol fluids (sz. 975 & 1100 only)
- T = Filter Breather (sz. 75, 90, 150, 165, 185, 210, 270 only) - (includes oil separator on 2 bolt versions sizes 75, 165, 185 only)
- C = Outlet check valves (sizes 975, 1100 only) G = BSPP threaded outlet
- DTxx = Down tube (xx length in inches - up to 12 inches) 4L = 4 Bolt mounting flange (sizes 90-185)
- DSxx = Dip stick (xx length in inches) 2MO = Indicator with Deutsch Connector (FD indicator only)
- D = Diffuser (sizes 75, 165, 185 only) SFREE = Element specially designed to minimize electrostatic charge generation

Replacement Element Model Code

0330 R 003 ON / V B6

Size _____
0050, 0075, 0090, 0150, 0165, 0185, 0210, 0270, 0330, 0500, 0660, 0850, 0975, 1100

Filtration Rating (micron) _____
1, 3, 5, 10, 15, 20 = ON
3, 5, 10, 20 = BN4HC (sz. 50, 975, 1100 only)
3, 10 = BN4AM 3, 5, 10, 20 = ECON2
40 = AM 25, 50, 100, 200 = W/HC
10, 20 = P/HC 10, 15 = MM

Element Media _____
ON, BN4HC, BN4AM, ECON2, AM, W/HC, P/HC, MM

Seals _____
(omit) = Nitrile rubber (NBR) (standard)
V = Fluorocarbon elastomer (FKM)
EPR = Ethylene propylene rubber (EPR)

Bypass Valve _____
(omit) = 43 psid (3 bar) (standard) B1 = 14.5 psid (1 bar)
B1.7 = 25 psid (1.7 bar) B6 = 87 psid (6 bar)
KB = no bypass

Supplementary Details _____
SO263 = (same as above) SFREE = (same as above)

Clogging Indicator Model Code

VR 2 D . X / V

Indicator Prefix _____
VR = Return Filters (sizes 330 to 851)
VMF = Mobile Filters (sizes 75 to 270)

Trip Pressure _____
1.4 = 20 psid (1.4 bar) 2 = 29 psid (2 bar)
5 = 72 psid (5 bar) (optional)

Type of Indicator _____
A = No indicator, plugged port
B = Pop-up indicator (auto reset - static only)
BM = Pop-up indicator (manual reset)
C = Electric switch - SPDT
E = Visual pressure gauge
F = Electric pressure switch
FD = Electric pressure switch w/Deutsch Connector

Modification Number _____

Supplementary Details _____
2MO = Deutsch Connector (male)

Seals _____
(omit) = Nitrile rubber (NBR) (standard)
V = Fluorocarbon elastomer (FKM)
EPR = Ethylene propylene rubber (EPR)

(For additional details and options, see Section H - Clogging Indicators.)

LOW PRESSURE FILTERS

Clogging Indicator Locations

RFM 75/165/185

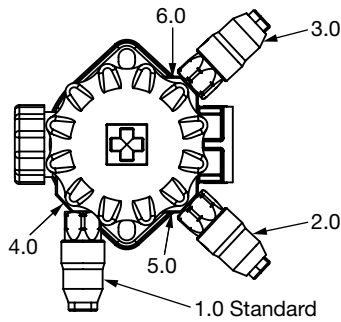

RFM 75/165/185 (2 Bolt Mount)

Type No.	Location of Clogging Indicator	Indicator Model
1.X	Clogging Indicator left back 90° to Inlet	VMF...
2.X	Clogging Indicator left front 45° to Inlet	VMF...
3.X	Clogging Indicator right front 45° to Inlet	VMF...
4.X	Clogging Indicator left back 135° to Inlet	VMF...
5.X	Clogging Indicator left front 90° to Inlet	VMF...
6.X	Clogging Indicator right front 90° to Inlet	VMF...

RFM 75/165/185/-4L

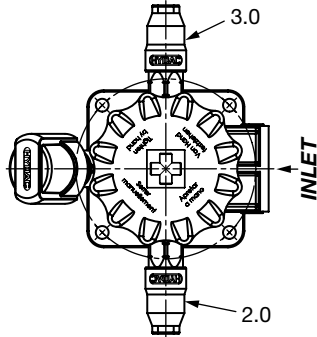

RFM 75/165/185 - Single Port (4 Bolt Mount)

Type No.	Location of Clogging Indicator	Indicator Model
2.X	Clogging Indicator left front 90° to Inlet	VMF...
3.X	Clogging Indicator right front 90° to Inlet	VMF...

RFM 75/165/185/-4L - Multi-Port

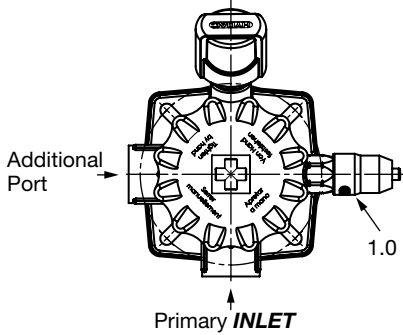

RFM 75/165/185 - Multi-Port (4 Bolt Mount)

Type No.	Location of Clogging Indicator	Indicator Model
1.X	Clogging Indicator right of primary Inlet, 90° to Inlet	VMF...

RFM 90/150

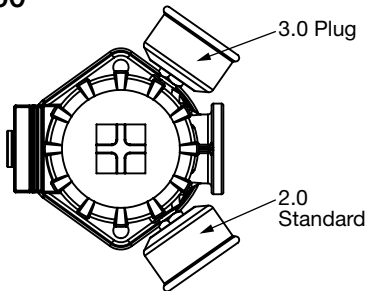

Type No.	Location of Clogging Indicator	Indicator Model
2.X	Clogging Indicator left front 45° to Inlet	VMF...
3.X	Clogging Indicator right front 45° to Inlet	VMF...

RFM 90/150/-4L

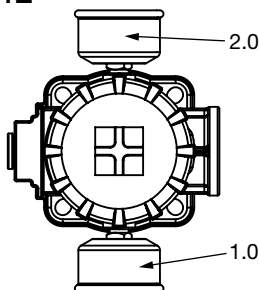

Clogging Indicator Locations (cont'd)

RFM 210/270

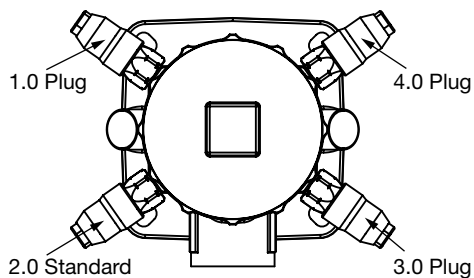

Type No.	Location of Clogging Indicator	Indicator Model
1.X	Clogging Indicator left back 45° to Inlet	VMF...
2.X	Clogging Indicator left front 45° to Inlet	VMF...
3.X	Clogging Indicator right front 45° to Inlet	VMF...
4.X	Clogging Indicator right back 45° to Inlet	VMF...

RFM 330/500

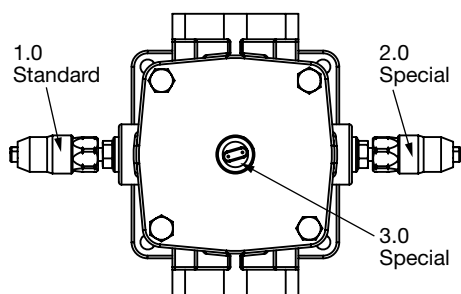

Type No.	Location of Clogging Indicator	Indicator Model
1.X	Clogging Indicator left 90° to Inlet	VR...
2.X	Clogging Indicator right 90° to Inlet	VR...
3.X	Clogging Indicator on Top	VR...

RFM 661/851

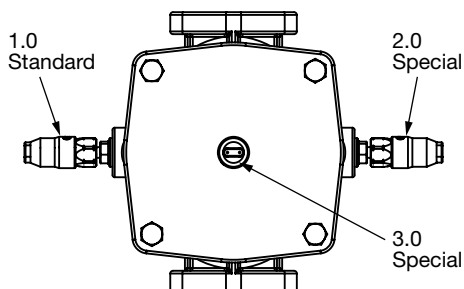

Type No.	Location of Clogging Indicator	Indicator Model
1.X	Clogging Indicator left 90° to Inlet	VR...
2.X	Clogging Indicator right 90° to Inlet	VR...
3.X	Clogging Indicator on Top	VR...

LOW PRESSURE FILTERS

Dimensions

RFM 50 - 4L

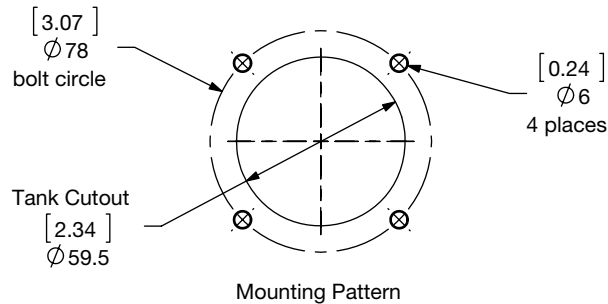
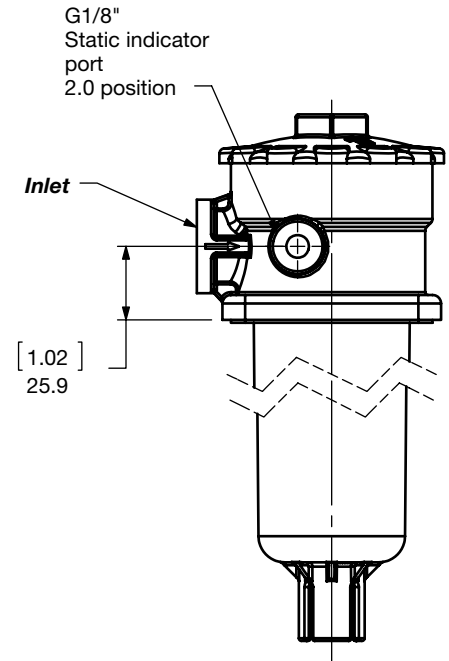
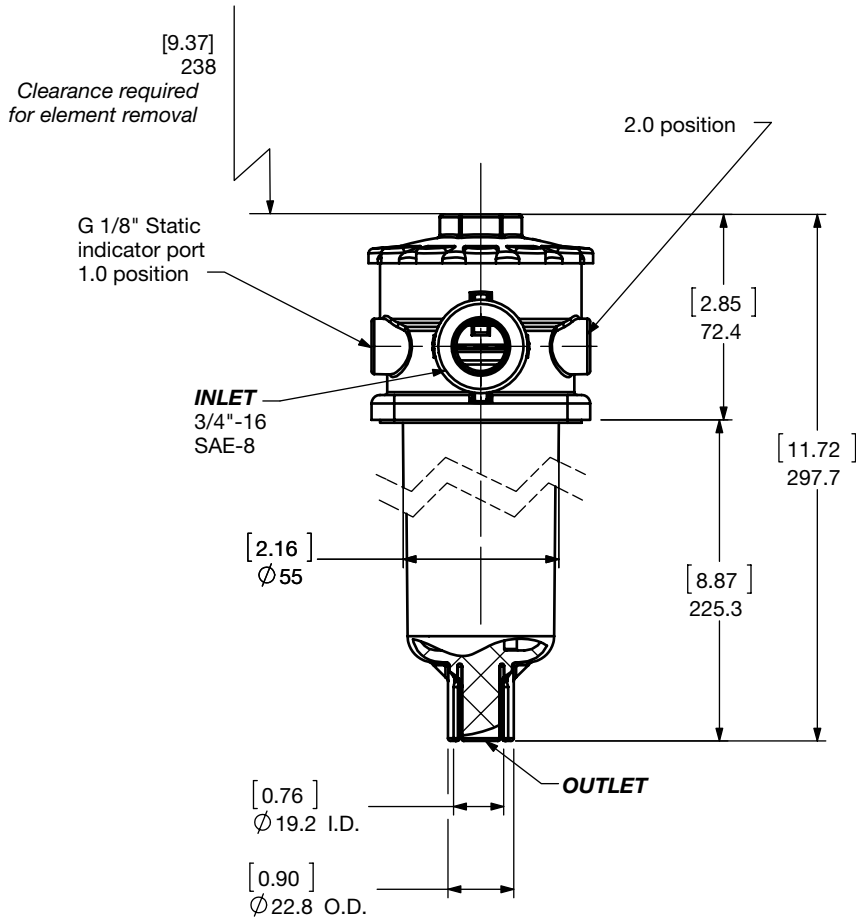
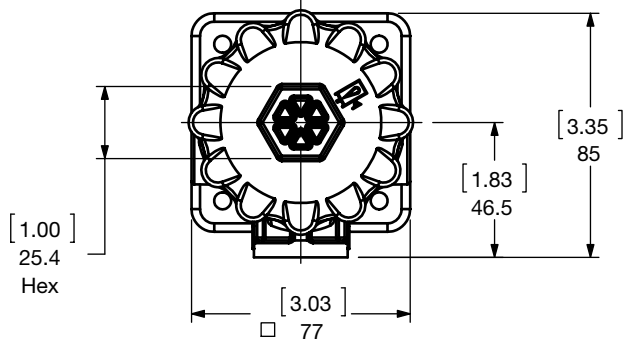

Size	50
Weight (lbs.)	1.5

Dimensions shown are [inches] millimeters for general information and overall envelope size only. Weights listed include element. For complete dimensions please contact HYDAC to request a certified print.

Dimensions

RFM 75/165/185 (2 Bolt)

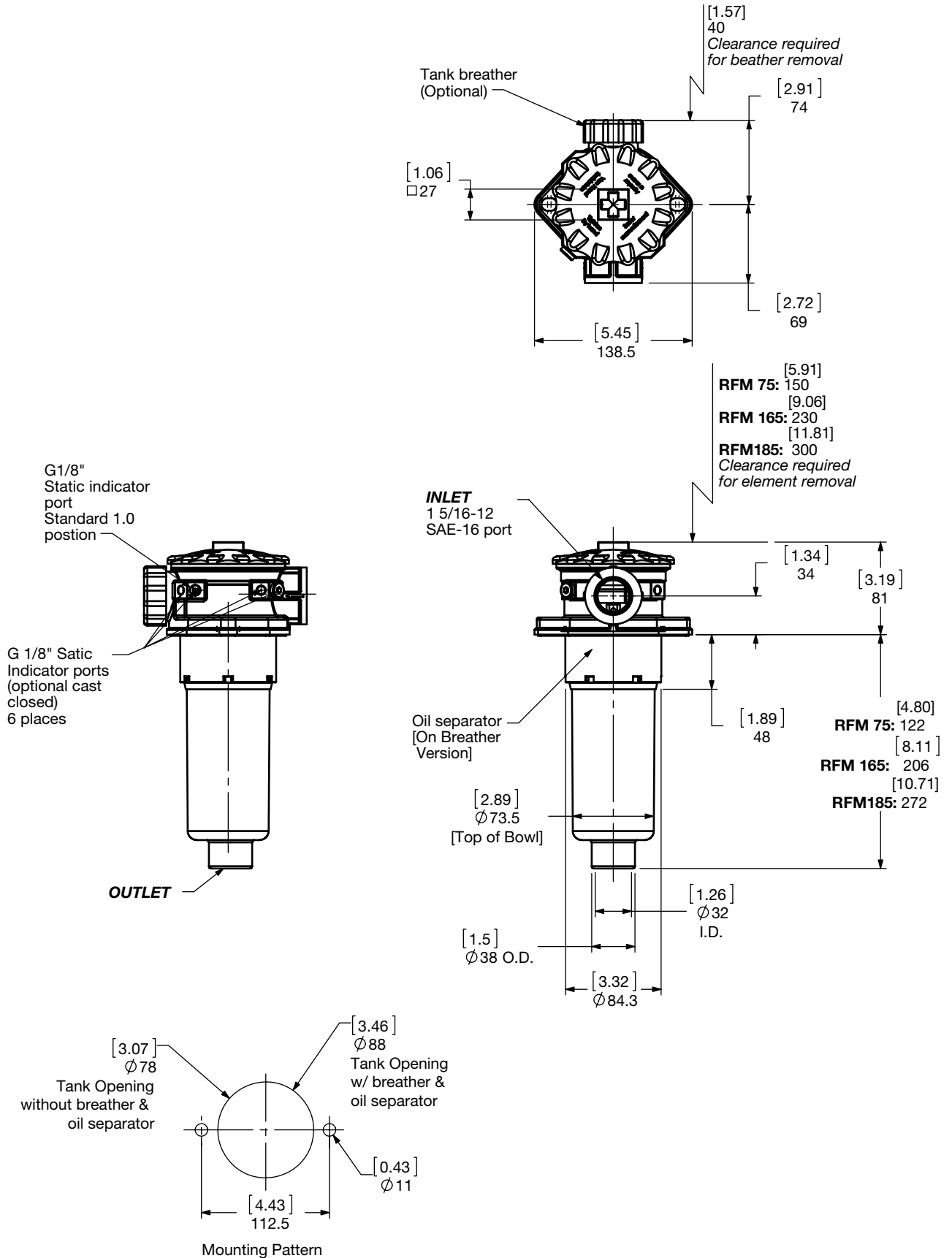

Size	75	165	185
Weight (lbs.)	2.0	2.5	2.6

Dimensions shown are [inches] millimeters for general information and overall envelope size only. Weights listed include element. For complete dimensions please contact HYDAC to request a certified print.

LOW PRESSURE FILTERS

Dimensions

RFM 75/165/185 - 4L Single Port (4 Bolt)

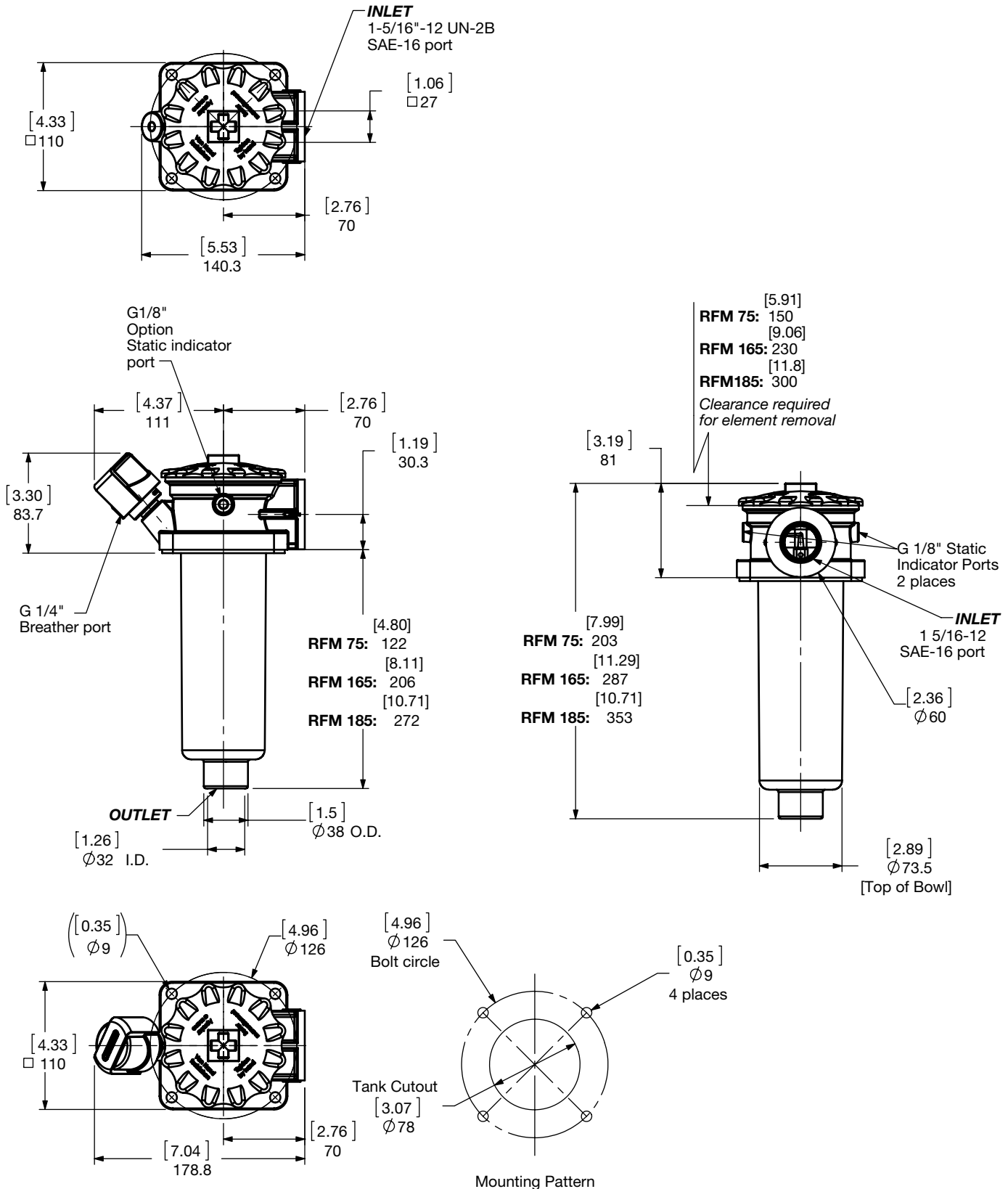

Note: Breather (BF10
With Anti Splash)

Size	75	165	185
Weight (lbs.)	2.0	2.5	2.6

Dimensions shown are [inches] millimeters for general information and overall envelope size only. Weights listed include element.
For complete dimensions please contact HYDAC to request a certified print.

Dimensions

RFM 75/165/185 - 4L Multi Port (4 Bolt)

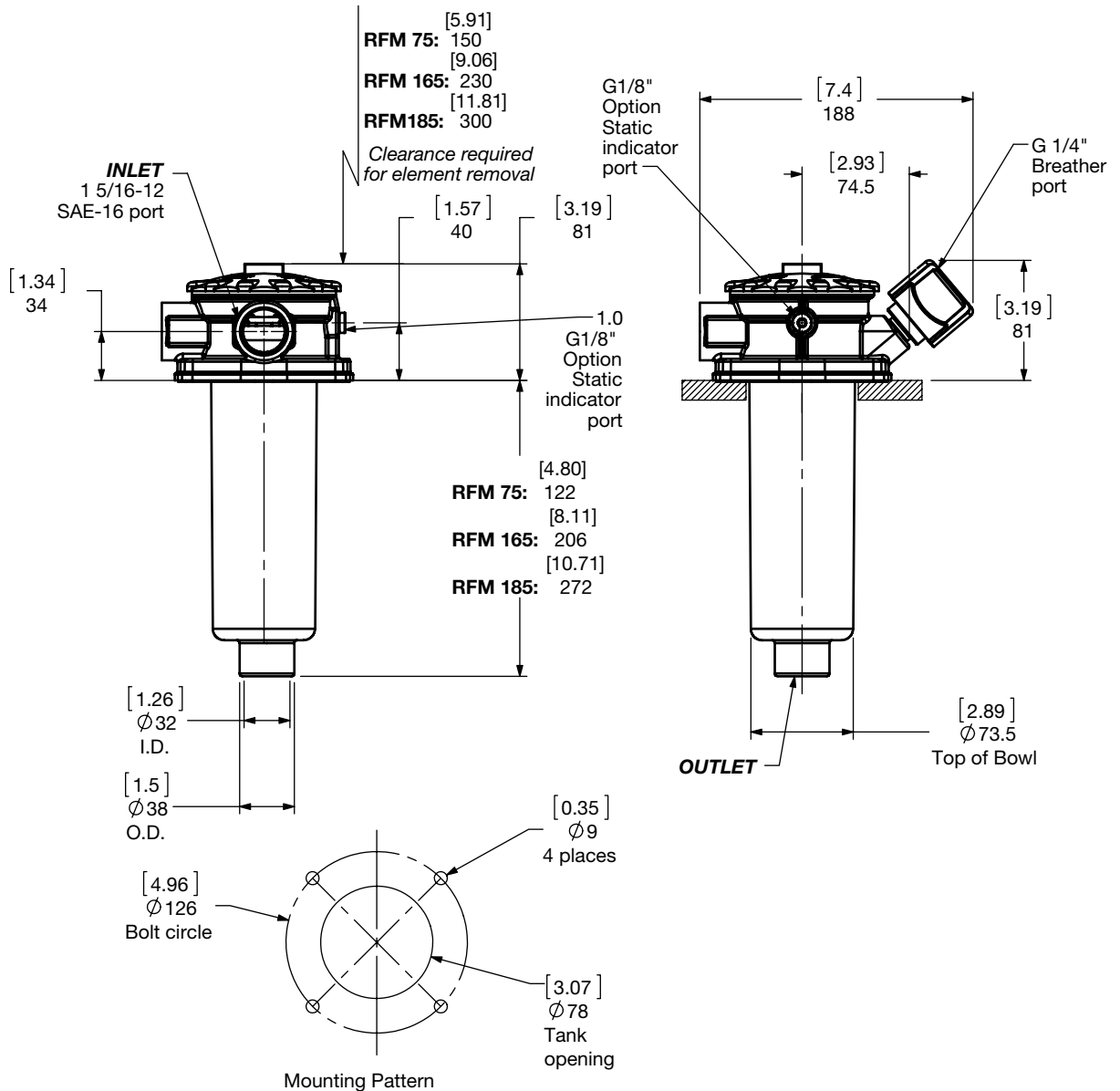
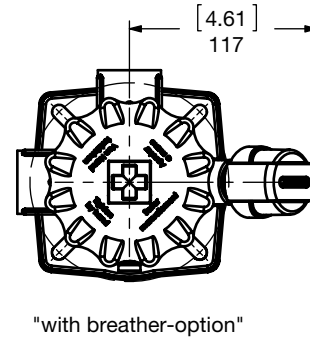
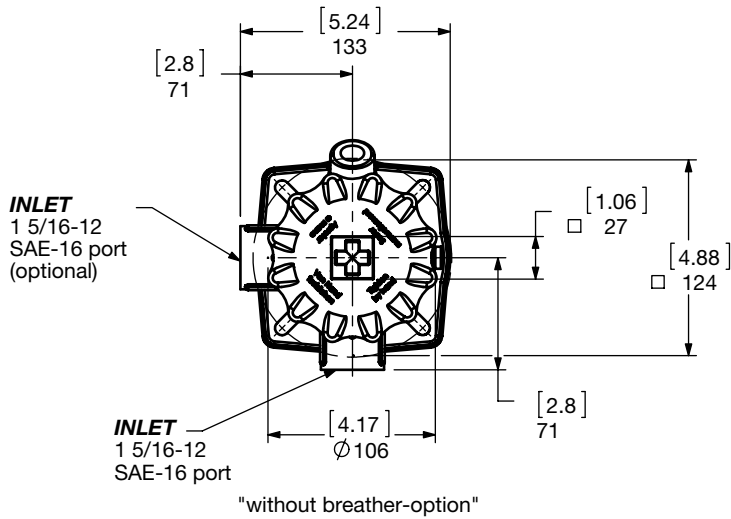

Size	75	165	185
Weight (lbs.)	2.0	2.5	2.6

Dimensions shown are [inches] millimeters for general information and overall envelope size only. Weights listed include element. For complete dimensions please contact HYDAC to request a certified print.

LOW PRESSURE FILTERS

Dimensions

RFM 90-150 (2 Bolt)

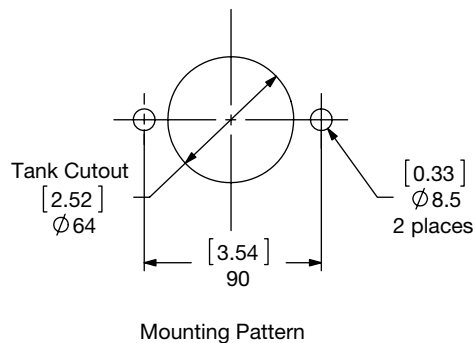
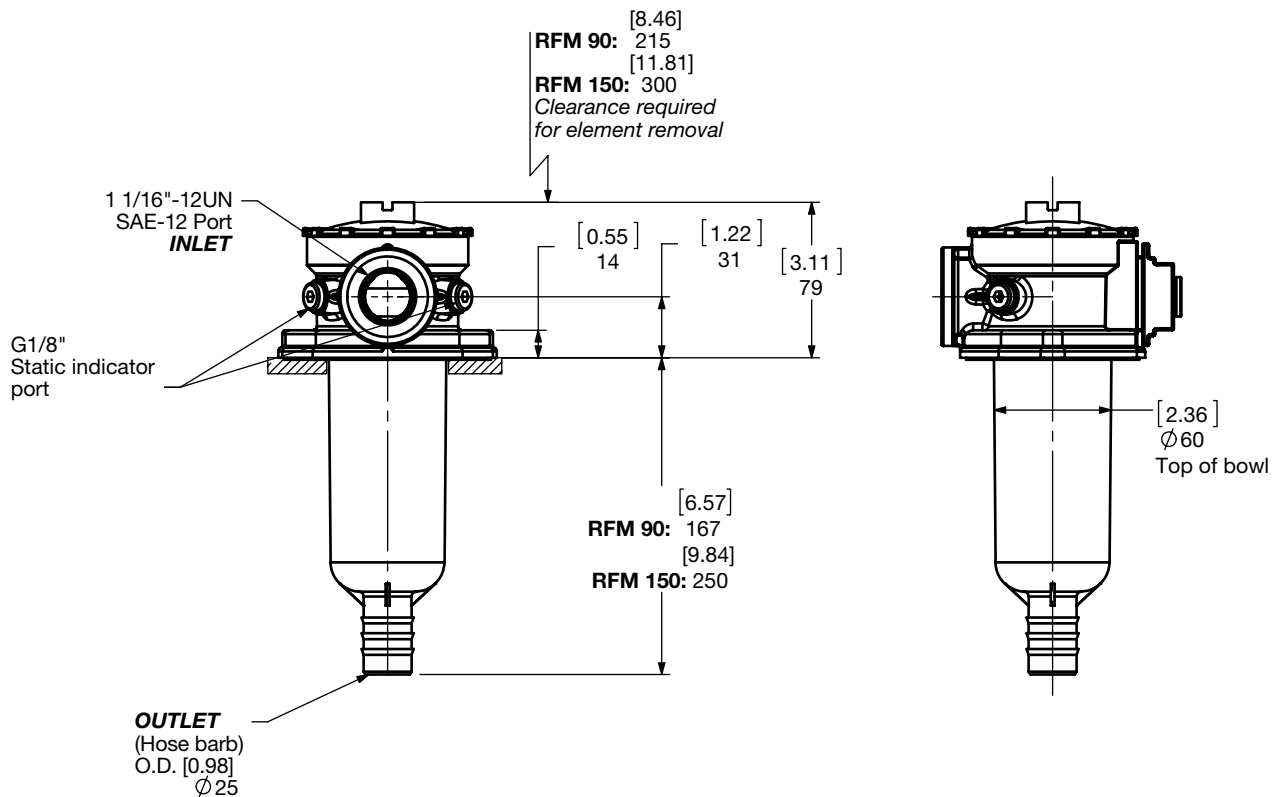
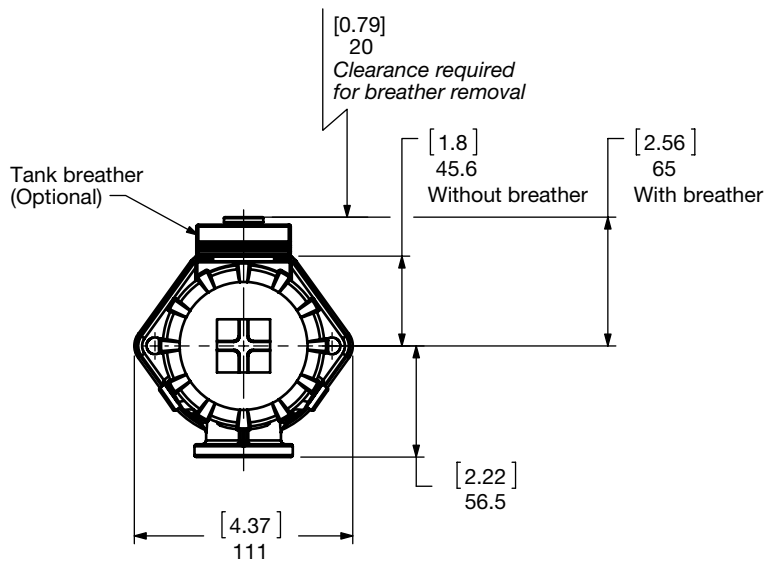

Size	90	150
Weight (lbs.)	1.2	1.7

Dimensions shown are [inches] millimeters for general information and overall envelope size only. Weights listed include element. For complete dimensions please contact HYDAC to request a certified print.

Dimensions

RFM 90-150 - 4L (4 Bolt)

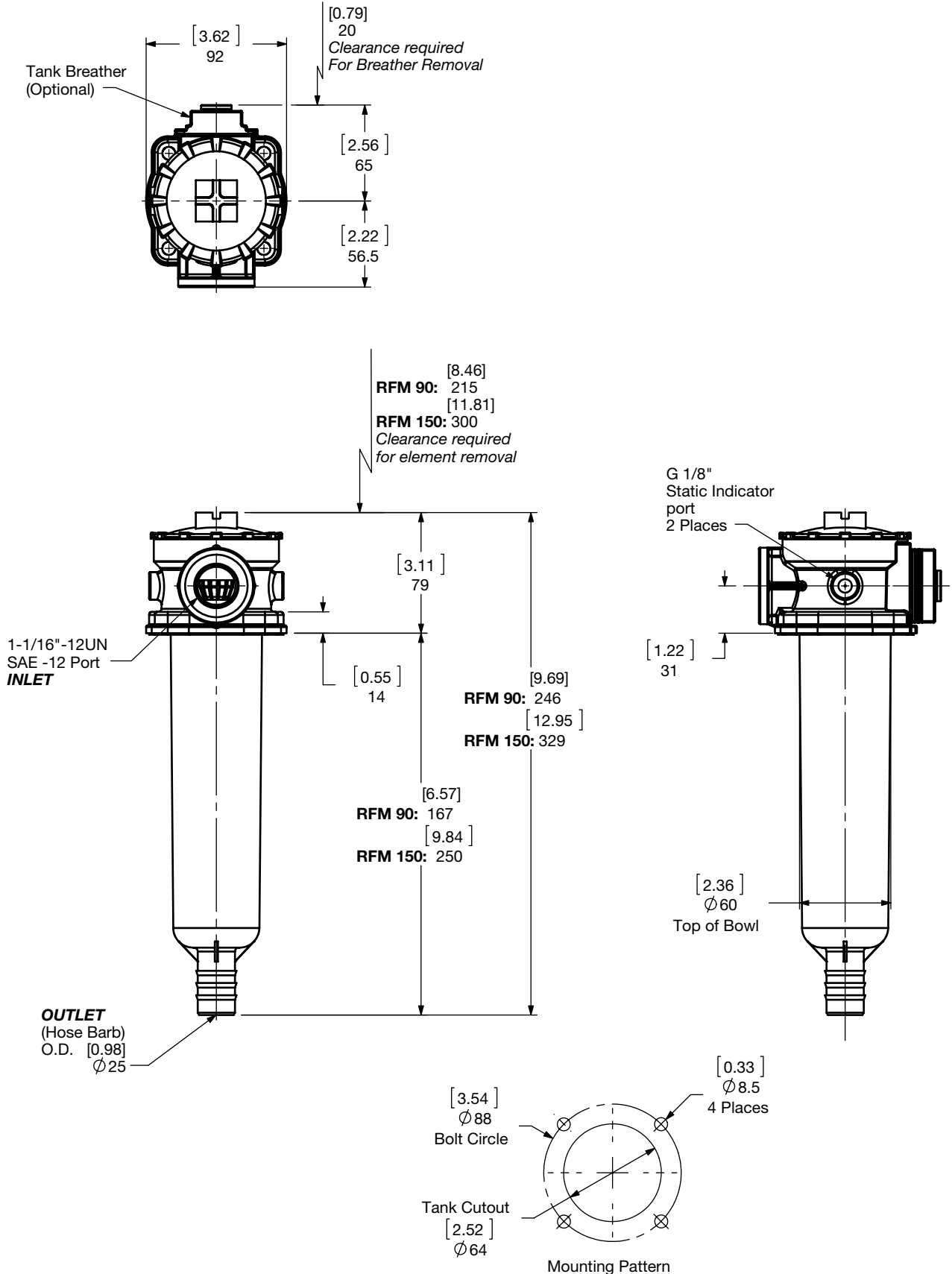

Size	90	150
Weight (lbs.)	1.2	1.7

Dimensions shown are [inches] millimeters for general information and overall envelope size only. Weights listed include element. For complete dimensions please contact HYDAC to request a certified print.

LOW PRESSURE FILTERS

Dimensions

RFM 210/270

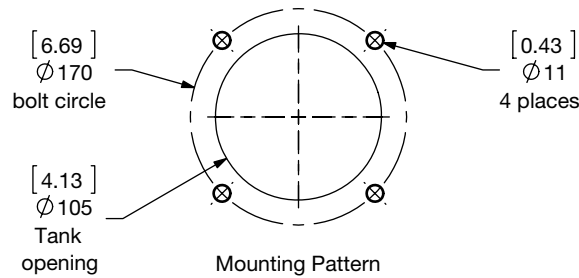
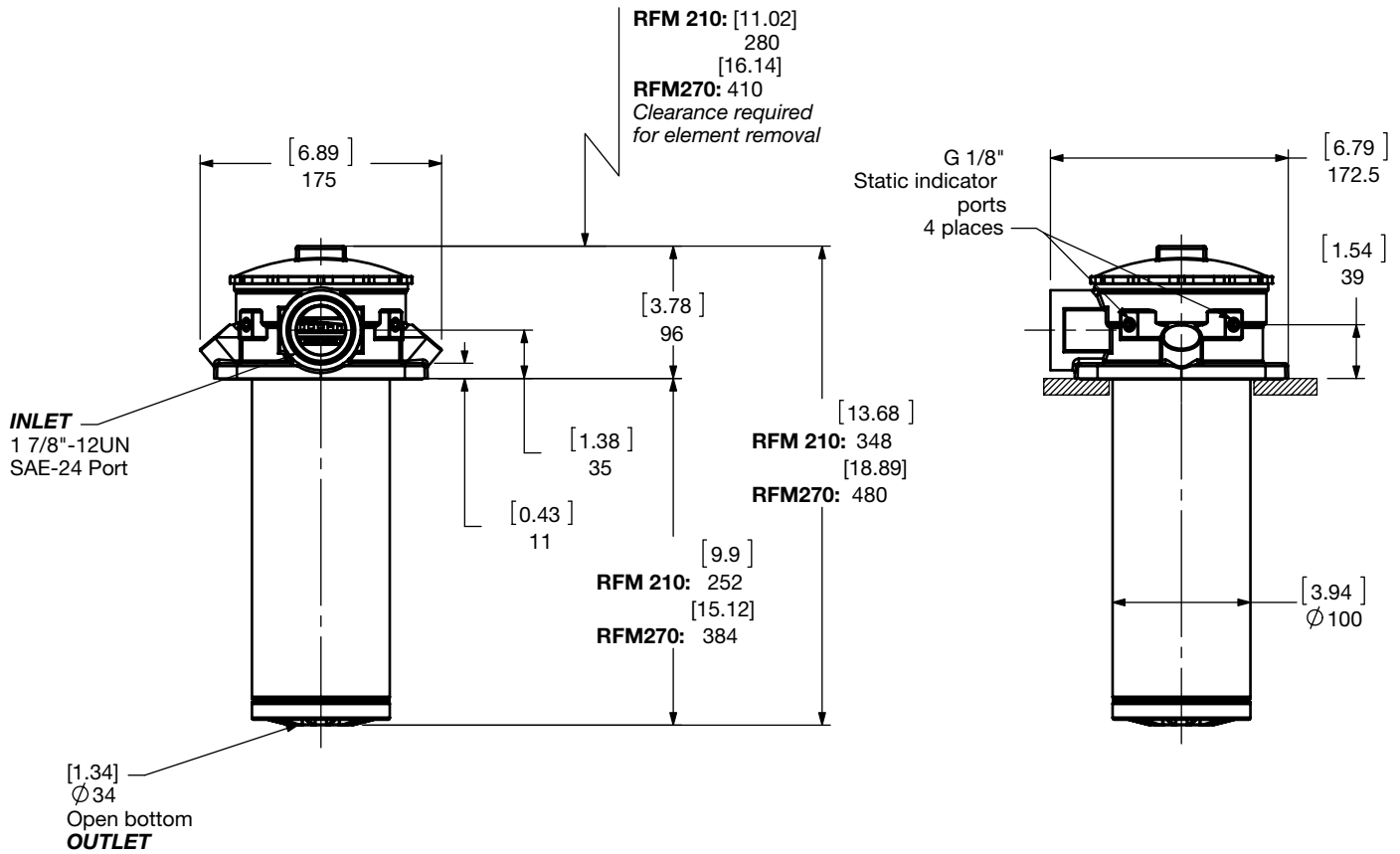
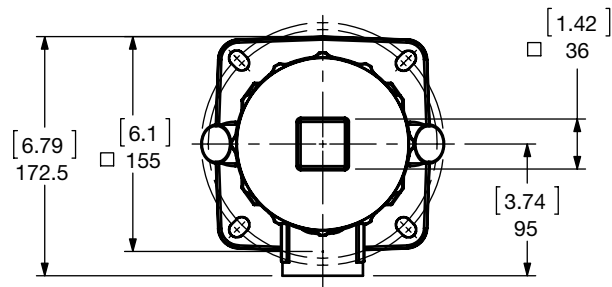

Size	210	270
Weight (lbs.)	7	9.5

Dimensions shown are [inches] millimeters for general information and overall envelope size only. Weights listed include element. For complete dimensions please contact HYDAC to request a certified print.

Dimensions RFM 330/500

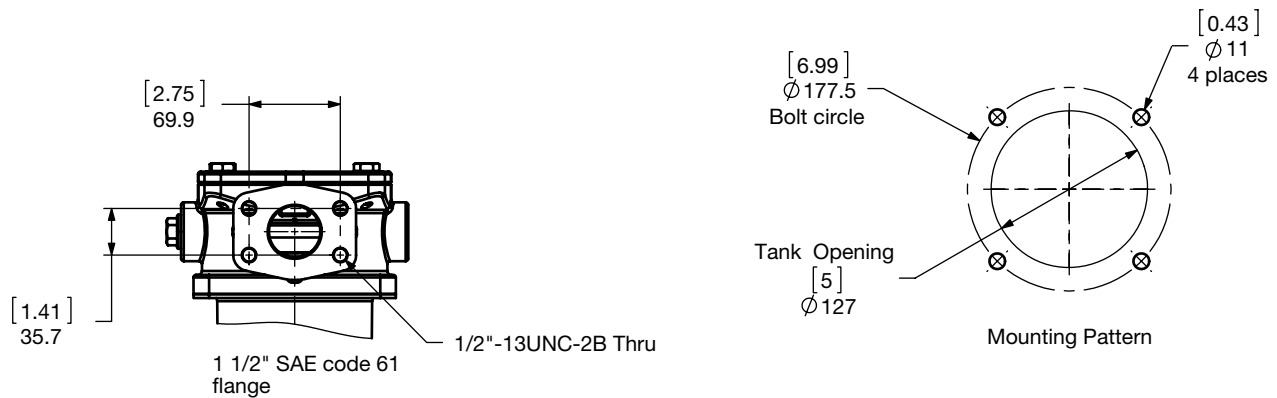
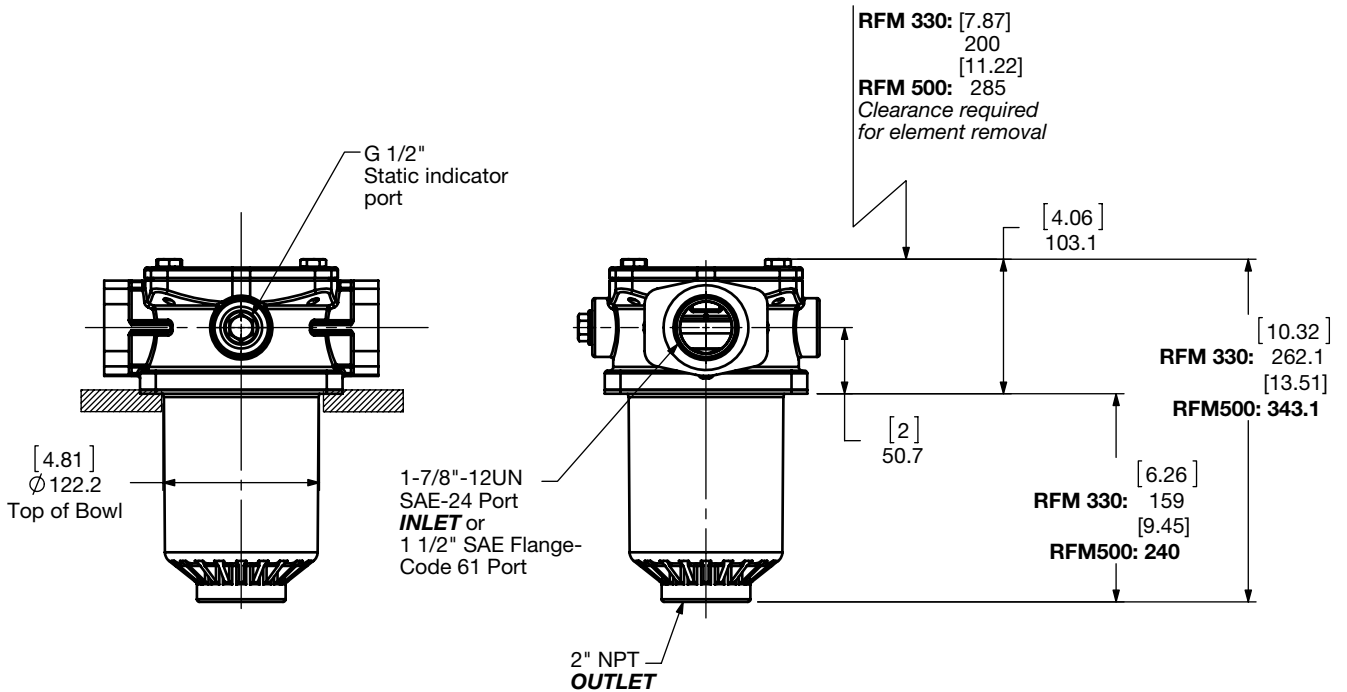
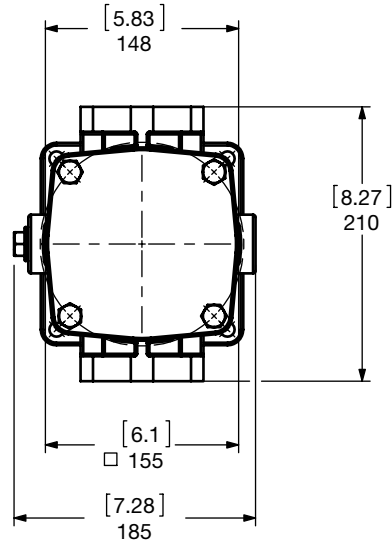

Size	330	500
Weight (lbs.)	8.6	10

Dimensions shown are [inches] millimeters for general information and overall envelope size only. Weights listed include element. For complete dimensions please contact HYDAC to request a certified print.

LOW PRESSURE FILTERS

Dimensions

RFM 661/851

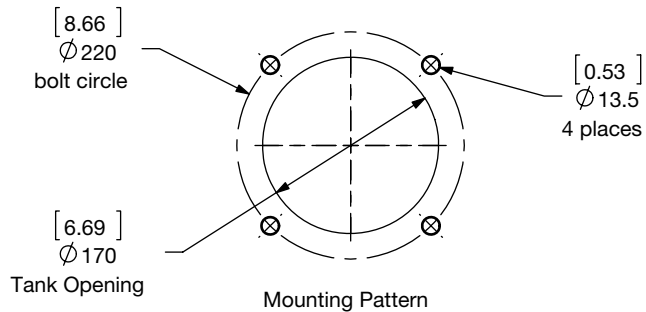
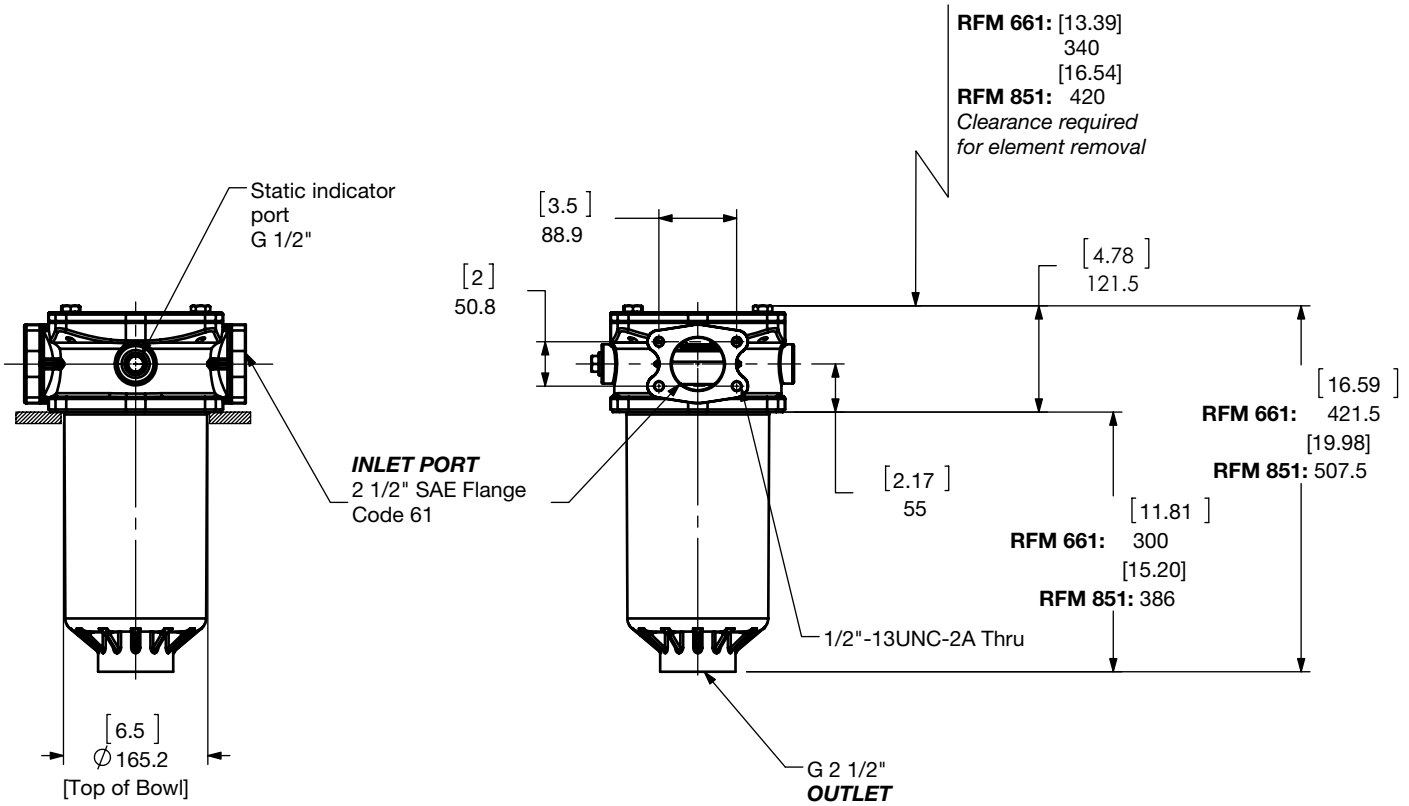
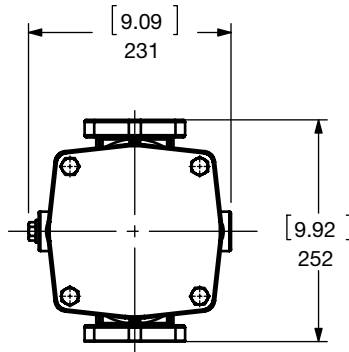

Size	661	851
Weight (lbs.)	19.9	23.2

Dimensions shown are [inches] millimeters for general information and overall envelope size only. Weights listed include element. For complete dimensions please contact HYDAC to request a certified print.

Dimensions RFM 975/1100

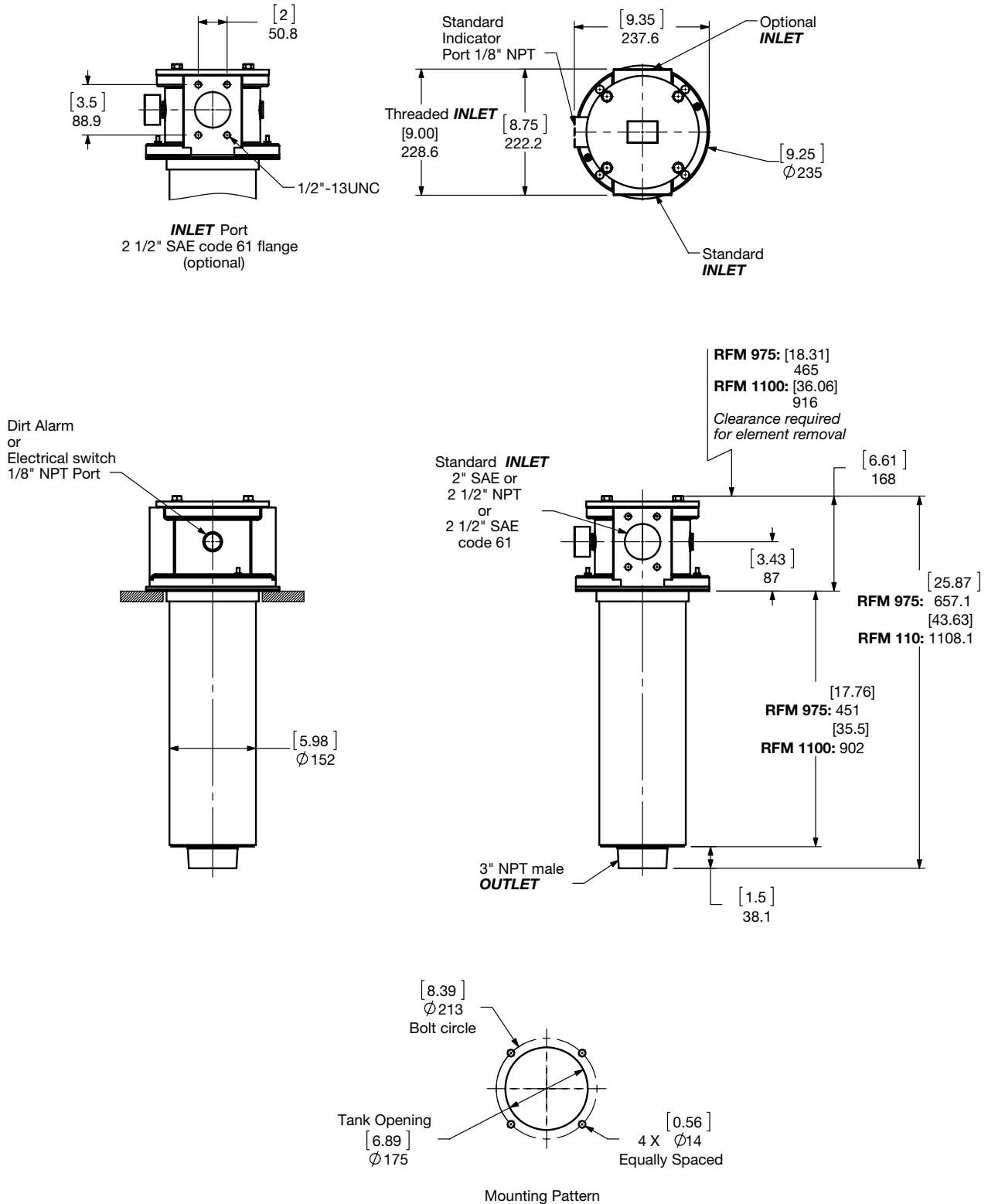

Size	975	1100
Weight (lbs.)	37	52

Dimensions shown are [inches] millimeters for general information and overall envelope size only. Weights listed include element. For complete dimensions please contact HYDAC to request a certified print.

LOW PRESSURE FILTERS

Sizing Information

Total pressure loss through the filter is as follows:

$$\text{Assembly } \Delta P = \text{Housing } \Delta P + \text{Element } \Delta P$$

Housing Curve:

Pressure loss through housing is as follows:

$$\text{Housing } \Delta P = \text{Housing Curve } \Delta P \times \frac{\text{Actual Specific Gravity}}{0.86}$$

Adjustments must be made for viscosity & specific gravity of the fluid to be used! (see "Sizing HYDAC Filter Assemblies" in Section B - Overview)

RFM 50/-4L Housing

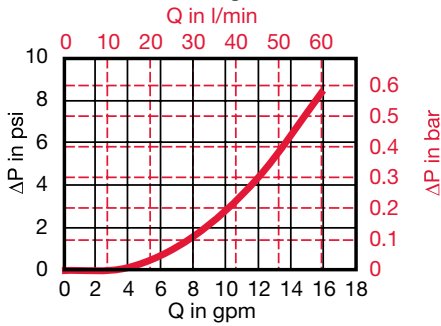

RFM 75/165/185 & RFM 75/165/185/-4L Housing

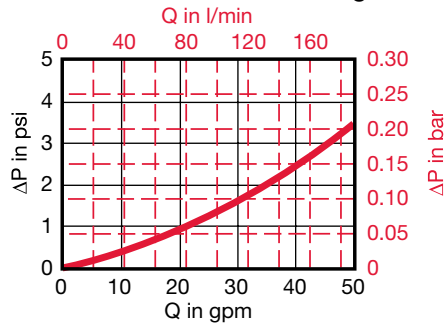

RFM 90/150 & RFM 90/150/-4L Housing

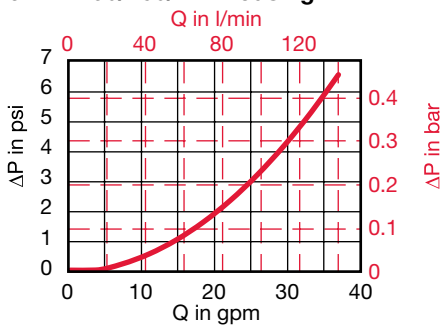

RFM 210 / 270 Housing

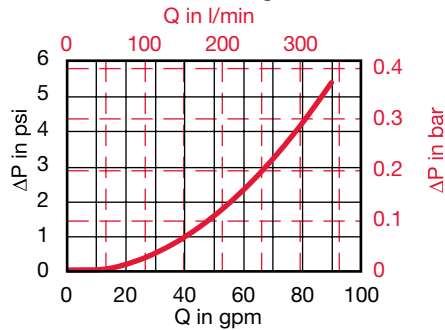

RFM 330/500 Housing

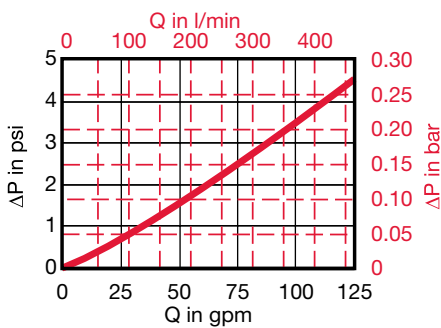

RFM 661/851 Housing

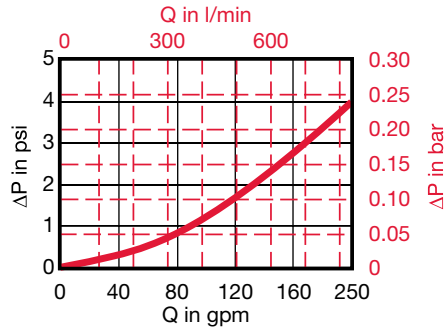

RFM 975 / 1100 Housing

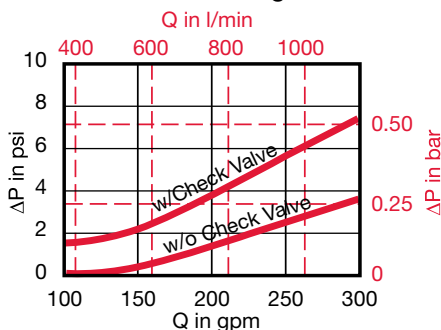

Element K Factors

$$\Delta P \text{ Elements} = \text{Elements (K)} \times \text{Flow Factor} \times \text{Flow Rate (gpm)} \times \frac{\text{Actual Viscosity (SUS)}}{141 \text{ SUS}} \times \frac{\text{Actual Specific Gravity}}{0.86}$$

(From Tables Below)

Betamicron		...R...BN4HC			
Size	3 µm	5 µm	10 µm	20 µm	
0975 R XXX BN4HC	0.050	0.040	0.030	0.020	
1100 R XXX BN4HC	0.030	0.020	0.020	0.010	

Optimicron		...R...ON				
Size	1 µm	3 µm	5 µm	10 µm	15 µm	20 µm
0050 R XXX ON	N.A.	N.A.	N.A.	0.296	N.A.	N.A.
0075 R XXX ON	1.405	1.065	0.735	0.401	0.263	0.241
0090 R XXX ON	1.235	0.719	0.521	0.333	0.236	0.176
0165 R XXX ON	0.774	0.518	0.404	0.221	0.123	0.133
0185 R XXX ON	0.571	0.408	0.315	0.161	0.091	0.077
0210 R XXX ON	0.311	0.18	0.14	0.084	0.055	0.048
0270 R XXX ON	0.201	0.116	0.091	0.054	0.036	0.031
0330 R XXX ON	0.444	0.204	0.15	0.081	0.07	0.056
0500 R XXX ON	0.289	0.143	0.104	0.06	0.046	0.038
0660 R XXX ON	0.196	0.093	0.066	0.037	0.031	0.025
0850 R XXX ON	0.152	0.072	0.055	0.032	0.024	0.02

ECOMICRON		...R...ECON2			
Size	3 µm	5 µm	10 µm	20 µm	
0090 R XXX ECON2	0.818	0.554	0.368	0.176	
0150 R XXX ECON2	0.488	0.329	0.220	0.104	
0165 R XXX ECON2	0.615	0.428	0.247	0.132	
0185 R XXX ECON2	0.488	0.335	0.181	0.099	
0195 R XXX ECON2	0.362	0.247	0.132	0.071	
0330 R XXX ECON2	0.230	0.148	0.093	0.066	
0500 R XXX ECON2	0.165	0.104	0.071	0.044	
0660 R XXX ECON2	0.104	0.066	0.044	0.027	
0850 R XXX ECON2	0.082	0.055	0.038	0.022	

MOBILEMICRON		...R...MM		
Size	8 µm	10 µm	15 µm	
0075 R XXX MM	0.265	0.265	0.166	
0090 R XXX MM	0.252	0.252		
0150 R XXX MM	0.114	0.114	0.071	
0165 R XXX MM	0.146	0.146	0.091	
0185 R XXX MM	0.108	0.108	0.068	
0210 R XXX MM	0.052	0.052	0.032	
0270 R XXX MM	0.032	0.032	0.020	
0330 R XXX MM	0.078	0.078	0.049	
0500 R XXX MM	0.052	0.052	0.032	
0660 R XXX MM	0.030	0.030	0.019	
0850 R XXX MM	0.023	0.023	0.014	

Betamicron/Aquamicron		...R...BN4AM	
Size	3 µm	10 µm	
0330 R XXX BN4AM	0.477	0.165	
0500 R XXX BN4AM	0.313	0.11	
0660 R XXX BN4AM	0.192	0.066	
0850 R XXX BN4AM	0.154	0.049	

Aquamicron		...R...AM	
Size	40 µm		
0330 R 040 AM	0.115		
0500 R 040 AM	0.076		
0660 R 040 AM	0.051		
0850 R 040 AM	0.040		

Wire Mesh		...R...W/HC	
Size	25, 50, 100, 200 µm		
0075 R XXX W/HC	0.020		
0090 R XXX W/HC	0.017		
0150 R XXX W/HC	0.010		
0165 R XXX W/HC	0.011		
0185 R XXX W/HC	0.050		
0195 R XXX W/HC	0.037		
0210 R XXX W/HC	0.004		
0270 R XXX W/HC	0.002		
0330 R XXX W/HC	0.011		
0500 R XXX W/HC	0.007		
0660 R XXX W/HC	0.004		
0850 R XXX W/HC	0.003		

Polyester		...R...P/HC	
Size	10 µm	20 µm	
0075 R XXX P/HC	0.071	0.036	
0090 R XXX P/HC	0.058	0.029	
0150 R XXX P/HC	0.040	0.017	
0165 R XXX P/HC	0.033	0.016	
0185 R XXX P/HC	0.029	0.016	
0195 R XXX P/HC	0.018	0.009	
0210 R XXX P/HC	0.018	0.010	
0270 R XXX P/HC	0.009	0.004	
0330 R XXX P/HC	0.016	0.008	
0500 R XXX P/HC	0.011	0.005	
0660 R XXX P/HC	0.008	0.004	
0850 R XXX P/HC	0.007	0.003	

S.S. Wire Mesh "R"		...R...V US UNITS			
Size	3 µm	5 µm	10 µm	20 µm	
0330 R XXX V	0.115	0.093	0.060	0.044	
0500 R XXX V	0.082	0.066	0.044	0.027	
0660 R XXX V	0.055	0.044	0.033	0.022	
0850 R XXX V	0.044	0.033	0.022	0.016	

All Element K Factors in psi / gpm.