



Advanced Crankcase Ventilation

ACV Series



protecting your equipment • protecting your environment

Solberg designs and manufactures high efficiency, open and closed, Advanced Crankcase Ventilation Systems to capture hazardous oil mist and particulate emissions (blow-by). This blow-by is vented from the crankcase of reciprocating engines. The ACV systems ensure environmental compliance, protect the engines turbocharger, intercoolers and inlet air filters while keeping the engine room free of oil mist.

Solberg's ACV series incorporates industry leading vacuum control technology paired with extremely long filter life. Choose from five size offerings as a stand-alone unit or a complete installation kit. For ease of installation, kit customization is available.

Applications Include

- Prime Power Engines
- Standby Generators
- Emergency Generators
- Marine Engines
- Gas Engines
- Diesel Engines
- Dual Fuel Engines
- Biogas/Digester Gas Engines
- CHP Applications
- And many other applications



Design Features

- Eliminates visible emissions (99%+ efficient at 0.3 um)
- High performance coalescing elements offer long life
- Flow ranges from 2 - 40 CFM (3 - 68 m³/hr) for single units
- Integrated vacuum control valve controls precise range of vacuum
- Diaphragm vacuum regulation valve design, no springs - No manual vacuum adjustment required
- Drain port for oil recovery
- Universal mounting bracket
- Available with installation kits
- Optional atmospheric bypass



ACV Specifications

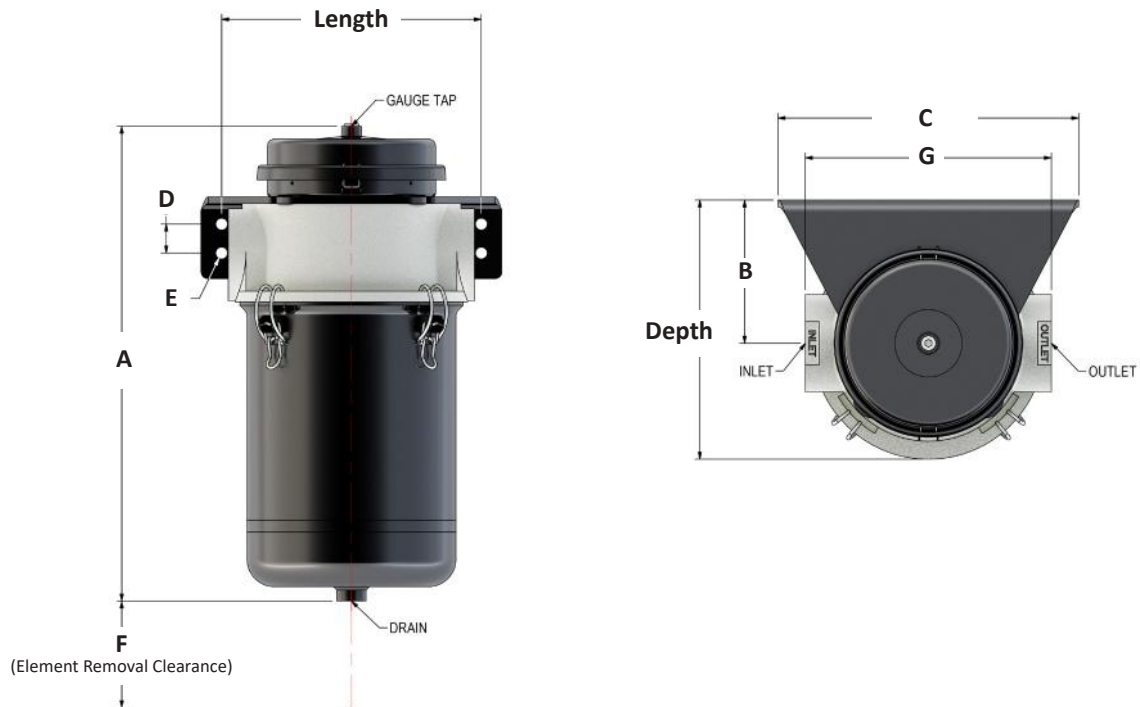

Part #	ACV0509(L/R)	ACV1017(L/R)	ACV2034(L/R)	ACV4068(L/R)
INLET/OUTLET	1" NPSC	2" NPSC	2" NPSC	3" NPT
DRAIN	.5" NPSC	.5" NPSC	.5" NPSC	1" NPSC
GAUGE TAP	.25" NPSC	.25" NPSC	.25" NPSC	.25" NPSC
FLOW RATE	5 CFM 8 m ³ /hr	10 CFM 17 m ³ /hr	20 CFM 34 m ³ /hr	40 CFM 68 m ³ /hr
LENGTH	3" 76 mm	9.5" 241 mm	9.5" 241 mm	6" 152 mm
DEPTH	9.1" 230 mm	9.5" 241 mm	9.5" 241 mm	12.7" 323 mm
A	16.6" 421 mm	17.4" 442 mm	22.3" 567 mm	28.6" 718 mm
B	5.5" 140 mm	5.3" 133 mm	5.3" 133 mm	7" 178 mm
C	4.5" 114 mm	11" 279 mm	11" 279 mm	8.5" 216 mm
D	-	1.1" 27 mm	1.1" 27 mm	1.06" 27 mm
E	0.56" 14 mm	0.43" 11 mm	0.43" 11 mm	0.43" 11 mm
F	0.5" 13 mm	0.5" 13 mm	0.5" 13 mm	0.5" 13 mm
G	7" 178 mm	9" 229 mm	9" 229 mm	13.5" 343 mm
NON VACUUM REGULATED "ACV-X" UNITS				
HEIGHT	14.3" 363 mm	15.2" 387 mm	20.1" 511 mm	26" 659 mm



SOLBERG
Filtration & Separation

1151 Ardmore Avenue. Itasca, IL 60143 USA

Sales/Service: 630.773.1363

Fax: 630.773.0727

sales@solbergmfg.com

www.solbergmfg.com