

# Pneumatic Drain System

## DSP and DSG

### Overview

The Pneumatic Drain System allows Solberg Liquid Separator units to be drained without stopping the process or any loss of vacuum. The liquid removed by the liquid separator flows under gravity into the drain pot. When the high level sensor detects the liquid, the drain pot is isolated from the liquid separator by the upper pneumatic ball valve. The bleed in valve then opens along with the bottom drain valve allowing the liquid to drain to atmosphere either by gravity (DSG) or forced by compressed air (DSP). When the lower level sensor triggers, the bleed in valve closes along with the bottom drain valve and the upper pneumatic ball valve opens to allow the process to repeat.

### Features

- Durable carbon steel construction
- Electronic level sensors which can be adjusted for sensitivity
- Bracket supports the system on a frame or wall
- Pneumatic ball valves in stainless steel, 24 VDC, operated by compressed air (ranges from 80-115 PSIG)
- Removable bottom section for easy maintenance
- Electrical controls are UL 508A listed



Holding Capacity (L)	Inlet & Outlet	Assembly Part Number Carbon Steel (SS Coating)	Dimensions - inches					Weight lbs.
			A	B	C	D	E	
5	1"	DSP-L005-100HC *	30 3/4	7 3/4	4 13/16	11 1/4	9 12/16	37 1/4

\*For gravity drain package, (DSG Series), contact factory for more information.

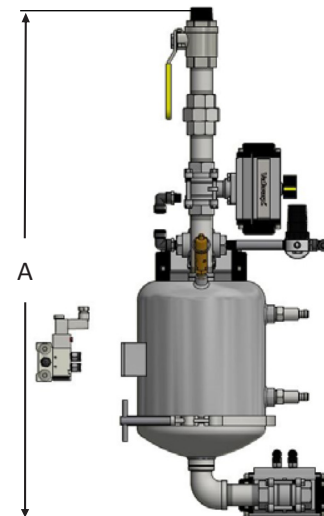
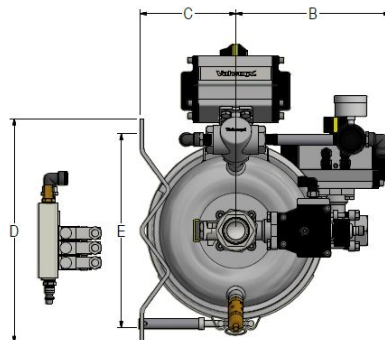

Rev: DSP-US1904K