

Exposed Inlet Filters

FT Series 1/4" - 14"

Features

- Exposed element for optimal air flow & low restriction
- Heavy gauge base with low pressure drop outlet pipe and center bracket design
- Corrosive resistant gray powder coat carbon steel

Technical Specifications

- Temp (continuous): min -15°F (-26°C) max 220°F (104°C)
- Filter change out differential: 15-20" H₂O over initial Δ P
- Pressure drop graphs available upon request
- Polyester: 99%+ removal efficiency standard to 5 micron
- Paper: 99%+ removal efficiency standard to 2 micron

Options ATEX Available

- Tap holes available
- Pressure drop indicator
- Various media for different environments
- Stainless steel construction
- Various nonstandard finishes and connection styles

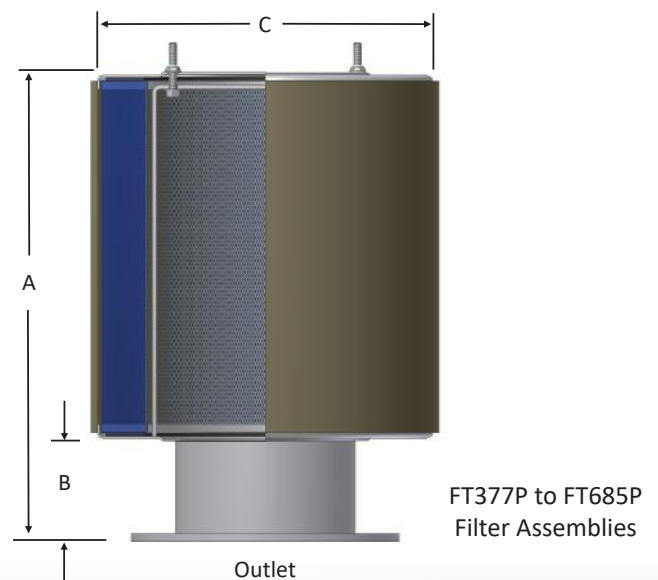
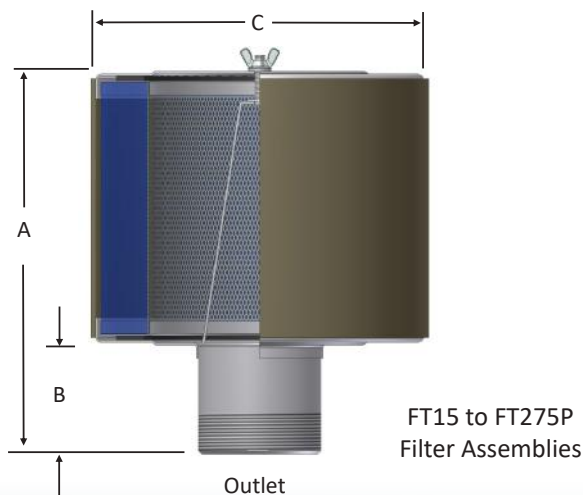

Rev: FT-US1903K

FT Series 1/4" - 14"

MPT Outlet	Assembly SCFM Rating	Assembly Part Number		Dimensions - inches			Suggested Service ht. inches	Approx. Weight lbs.	Replacement Element Part No.		Element SCFM Rating
		Polyester	Paper	A	B	C			Polyester	Paper	
1/2"	10	FT-15-050	FT-14-050	3 5/16	1	4 5/8	3	1	15	14	35
3/4"	25	FT-15-075	FT-14-075	3 5/8	1 1/4	4 5/8	3	1	15	14	35
1"	35	FT-15-100	FT-14-100	3 11/16	1 1/4	4 5/8	3	1	15	14	35
1"	55	FT-19P-100	FT-18P-100	6 3/16	1 1/4	4 7/8	5	2	19P	18P	100
1 1/4"	70	FT-19P-125	FT-18P-125	6 11/16	1 3/4	4 7/8	5	2	19P	18P	100
1 1/2"	85	FT-19P-150	FT-18P-150	6 11/16	1 3/4	4 7/8	5	2	19P	18P	100
2"	135	FT-31P-200	FT-30P-200	7 1/4	2 1/4	6 1/2	5	3	31P	30P	195
2"	135	FT-231P-200	FT-230P-200	11 7/8	2 1/4	6 1/2	10	7	231P	230P	300
2 1/2"	195	FT-31P-250	FT-30P-250	7 1/2	2 1/2	6 1/2	5	4	31P	30P	195
2 1/2"	195	FT-231P-250	FT-230P-250	12 1/8	2 1/2	6 1/2	10	7	231P	230P	300
3"	300	FT-231P-300	FT-230P-300	12 5/8	3	6 1/2	10	8	231P	230P	300
3"	300	FT-235P-300	FT-234P-300	12 13/16	3	9	10	13	235P	234P	570
3"	300	FT-275P-300	FT-274P-300	13	3	12 1/2	10	22	275P	274P	1100
4"	520	FT-235P-400	FT-234P-400	13 11/16	4	9	10	17	235P	234P	570
4"	520	FT-275P-400	FT-274P-400	14	4	12 1/2	10	24	275P	274P	1100
5"	800	FT-275P-500	FT-274P-500	14	4	12 1/2	10	25	275P	274P	1100
6"	1100	FT-275P-600	FT-274P-600	15	5	12 1/2	10	27	275P	274P	1100

Flange Outlet	Assembly SCFM Rating	Assembly Part Number		Dimensions - inches			Suggested Service ht. inches	Approx. Weight lbs.	Replacement Element Part No.		Element SCFM Rating
		Polyester	Paper	A	B	C			Polyester	Paper	
4"	520	FT-235P-400F	FT-234P-400F	13 3/4	4	9	10	15	235P	234P	570
4"	520	FT-275P-400F	FT-274P-400F	14	4	13	10	24	275P	274P	1100
5"	800	FT-275P-500F	FT-274P-500F	14	4	13	10	28	275P	274P	1100
6"	1100	FT-275P-600F	FT-274P-600F	15	5	13	10	31	275P	274P	1100
8"	1800	FT-377P-800F	FT-376P-800F	21	6	15	15	53	377P	376P	1825
8"	1800	FT-385P-800F	FT-384P-800F	21	6	20 3/8	15	70	385P	384P	3300
10"	3300	FT-385P-1000F	FT-384P-1000F	21	6	20 3/8	15	80	385P	384P	3300
10"	3300	FT-685P-1000F	FT-384P(2)-1000F	35	6	20 3/8	29	95	685P	384P (2)	6600
12"	4700	FT-485P-1200F	FT-484P-1200F	28	6	20 3/8	22	90	485P	484P	4705
12"	4700	FT-685P-1200F	FT-384P(2)-1200F	35	6	20 3/8	29	100	685P	384P (2)	6600
14"	6000	FT-485P(2)-1400F	FT-484P(2)-1400F	49 3/16	6	20 3/8	22	160	485P (2)	484P (2)	9410

See Filter Assembly Technical Data for sizing guidelines.

125/150# Pattern Flange	Dimensions - inches			No. of Holes	Flange Thickness
	O.D.	B.C.	B.H.		
4"	9	7 1/2	0.75	8	0.5
5"	10	8 1/2	0.88	8	0.5
6"	11	9 1/2	0.88	8	0.5
8"	13 1/2	11 3/4	0.88	8	0.5
10"	16	14 1/4	1	12	0.5
12"	19	17	1	12	0.5

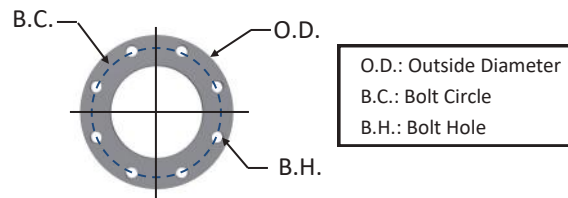

SOLBERG

www.solbergmfg.com

All model offerings and design parameters are subject to change without prior notice. Contact your representative or Solberg for the most current information.

Technical Data

Inlet Filter Assemblies

Applications & Equipment

- Industrial & Severe Duty
- Blowers - Side Channel & P.D.
- Breathers
- Fuel Cells
- Piston Compressors
- Screw Compressors
- Centrifugal Compressors
- Hydraulic Breathers – fine filtration
- Engines
- Fans
- Vacuum Pumps & Systems
- Construction\Contractor Industry
- Medical
- Pneumatic Conveying
- Waste Water Aeration
- Sparging
- Factory Air
- Vacuum Vent Breathers
- Cement Processing
- Power Plants
- Centralized Air Intakes

Identification

Standard Solberg assemblies should have an identification label/nameplate that gives the following information:

- Assembly Model #
- Replacement Element #

The part number designates the filter type, the element configuration and housing connection size. For example, the following part number identifies the filter as being an “F” design filter with a “385” element, “P” prefilter and 10” flange connection size.

F-385P-1000F

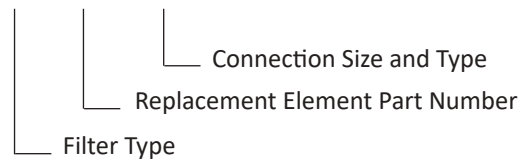

Typical Flow Curve

See chart for the typical flow curve for inlet filtration housing comparing the percentage of rated flow with typical pressure drop.

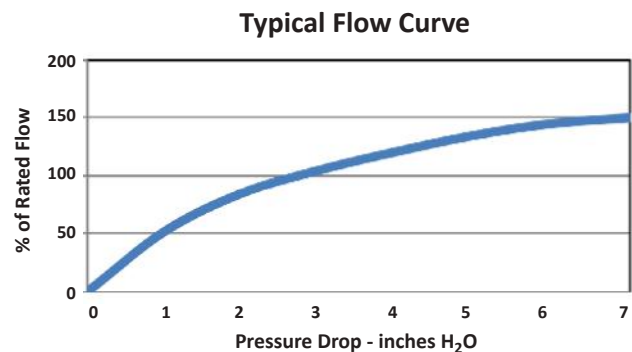

Rev: IFTD-US1904K

Inlet Filter Assemblies

Choosing the Best Filter for Your Equipment

A. When the connection & airflow is known:

1. select the appropriate connection style. (i.e.: MPT, Flange, NPSC, etc.)
2. check assembly SCFM (flow) rating. Compare with your required airflow.

(Note: Assembly flow ratings are based on 6,000 FPM or 30m/sec for a given connection size to achieve low pressure drop performance. When required flow exceeds assembly flow rating, the pressure drop through the outlet connection will increase. In such cases select by element SCFM (flow) rating.)

3. when required flow rating matches connection size; skip to “C. Selecting Elements”.

B. When the connection size is unknown, flexible, or the required flow rating exceeds assembly flow rating:

1. match required flow rating with the element flow rating.
2. choose related connection size.

C. Selecting Elements: The filter performance is influenced by the actual application duty and the equipment it is installed on. Regular maintenance checks and proper servicing is required.

Application Duty Descriptions:

Industrial Duty: clean workshop or clean outdoor environment - small element sizing is sufficient.

Severe Duty: dirty workshop, wastewater – medium to large element is recommended.

Extreme Duty: cement, steel making, plastics or dusty material conveying – largest element sizing is recommended.

1. Select media required by your application. Options include:

a. Standard media

1. Polyester: all purpose; withstands pulses, moisture, and oily air
2. Paper: mostly dry, smooth flow applications

b. Special Media: for a variety of micron levels and media types, see the “Filter Media Specifications” in the Replacement Element Section or contact Solberg.

2. Select element size by matching the element with the anticipated duty and upsize accordingly.

Filter Assembly Maintenance

Request the appropriate maintenance manual for more in-depth information from your Solberg representative or on our website www.solbergmfg.com.

Element Maintenance

Solberg elements should be replaced once the pressure drop reaches 15-20” H₂O above the initial pressure drop of the installation. Cleaning the element is also an option.

Solberg recommends replacing dirty elements for optimal performance. Any damage which results from by-pass or additional pressure drop created by element cleaning is the sole responsibility of the operator.

Note: The overall performance of a filter element is altered once cleaned. The initial pressure drop after subsequent cleanings will be greater than the original, clean pressure drop of the element. After each cleaning, the pressure drop will continue to increase. Under all circumstances, the initial pressure drop of the element needs to be maintained at less than 15” H₂O.

If the pressure drop exceeds 20” H₂O at start-up; it should be replaced with a new element. With many types of equipment, the maximum pressure drop allowed will be dictated by the ability of the equipment to perform to its rated capacity. Under all circumstances, the operator should avoid exceeding the manufacturer’s recommended maximum pressure drop for their specific equipment.



SOLBERG[®]

www.solbergmfg.com

All model offerings and design parameters are subject to change without prior notice.
Contact your representative or Solberg for the most current information.