

See-Through Liquid Separator

STS Series 1" - 4"

Overview

Inlet air with potentially harmful liquid and large particulate enters the housing and is separated by a baffling mechanism and directional air flow changes. The larger particles and liquid drop down and collect at the bottom of the separator. The float capsule within the separator screen rises with the liquid level until max capacity and limits the flow, thereby protecting the pump from damage.

Benefits

- Minimize the likelihood of damage to vacuum valves and pumps from liquid
- Protect installed equipment from liquid contamination by retrofitting STS separator
- Easy visual inspection with see-through housing
- Reduce piping costs with "T" style configuration
- Compact design for space restricted work areas

Features

- Compact design for space restrictions; min. service area
- Inlet above element for extended element life & maintenance intervals
- Corrosive resistant cast aluminum top with machined connections and integrated baffle design
- Shatter-resistant polycarbonate drop down bucket
- Stainless steel float capsule for emergency shut-off
- Stainless steel perforated float tube (SS expanded metal on 1" to 1 ½")
- Clamp style swing bolts on 3" & 4" standard
- Drain

Technical Specifications

- Vacuum Rating: medium vacuum service*
- Temp (continuous): min -15°F (-26°C) max 220°F (104°C)**



Options

- Cast head protective coatings
- Heavy duty carbon steel buckets available (CTS Series)
- Clamp style swing bolts on 1" to 2 ½"
- Spool piece extender
- Pressure drop gauge
- Taps for gauges and mounting brackets

Rev: STS-US1912K

STS Series 1" - 4"

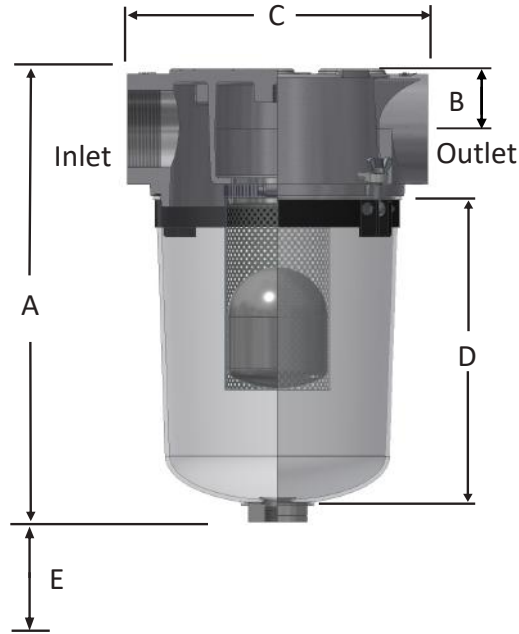

Inlet/Outlet		Assembly SCFM Rating	Assembly Part Number	Dimensions - inches				Suggested Service Ht. E	Holding Capacity gallons
Size	Type			A	B	C	D		
1"	NPSC	25	STS-100C	14 1/4"	1 1/2"	7"	11 1/4"	9"	0.4
1 1/4"	NPSC	40	STS-125C	14 1/4"	1 1/2"	7"	11 1/4"	9"	0.4
1 1/2"	NPSC	60	STS-150C	14 1/4"	1 1/2"	7"	11 1/4"	9"	0.4
2"	NPSC	105	STS-200C	17 1/4"	2"	9"	13 1/2"	9"	1
2 1/2"	FPT	115	STS-250C	17 1/4"	2"	9"	13 1/2"	9"	1
3"	FPT	240	STS-300C	20 9/16"	2 3/4"	13 1/2"	14 7/8"	9"	2
4"	FPT	250	STS-400C	20 9/16"	2 3/4"	13 1/2"	14 7/8"	9"	2

*See Vacuum Filter Technical Data for sizing guidelines and service data.

**Temperature for materials only.



SOLBERG[®]

www.solbergmfg.com

All model offerings and design parameters are subject to change without prior notice.
Contact your representative or Solberg for the most current information.

Technical Data

Inlet Vacuum Filters

Applications & Equipment

- Industrial & Severe Duty
- Vacuum Pumps & Systems: Roots, Rotary Vane, Screw, Piston
- Vacuum Packaging Equipment
- Vacuum Furnace
- Blowers: Side Channel & P.D.
- Vacuum Lifters
- Intake Suction Filters
- Food Industry
- Woodworking/Routers
- Ash Handling
- Printing Industry
- Medical/Hospital
- Remote Installations for Piston & Screw Compressors
- Paper Processing
- Waste Water Aeration
- Cement Processing
- Bag House Systems
- Vacuum Vent Breathers
- Chemical Processing
- Factory Automation Equipment
- Leak Detection Systems

Identification

Standard Solberg assemblies should have an identification label/nameplate that gives the following information:

- Assembly Model #
- Replacement Element #

The part number designates the filter type, the element configuration and housing connection size. For example, the following part number identifies the filter as being a “CSL” design filter with a “235” element, “P” prefilter and 4” flange connection size.

CSL-235P-400F

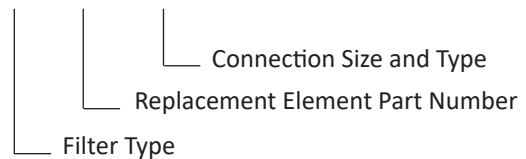

Vacuum Service Rating Chart

Threaded vacuum filter connections must be free of defect and properly sealed to achieve deeper vacuum levels. Vacuum service levels are given for reference only and serve as a guideline for product selection. Product certification and alternative designs are available for applications requiring deeper vacuum levels and specific leak rates. Please contact factory for details.

Vacuum Level	Pressure (mbar)	Pressure (Torr)	Pressure (Pa)
Atmospheric Pressure	1013	760	1.013x10 ⁺⁵
Coarse Vacuum	1013 to 33	760 to 25	1x10 ⁺⁵ to 3x10 ⁺³
Medium Vacuum	33 to 1.3x10 ⁻³	25 to 1x10 ⁻³	3x10 ⁺³ to 1x10 ⁻¹
High Vacuum	1.3x10 ⁻³ to 1.3x10 ⁻⁹	1x10 ⁻³ to 1x10 ⁻⁹	1x10 ⁻¹ to 1x10 ⁻⁷

Rev: IVTD-US1904K

Inlet Vacuum Filters

Choosing the Best Filter for Your Equipment

A. When the connection & airflow is known:

1. select the appropriate connection style. (i.e.: MPT, Flange, NPSC, etc.)
2. check assembly SCFM (flow) rating. Compare with your required airflow.

(Note: Assembly flow ratings are based on 6,000 FPM or 30m/sec for a given connection size to achieve low pressure drop performance. When required flow exceeds assembly flow rating, the pressure drop through the outlet connection will increase. In such cases select by element SCFM (flow) rating.)

3. when required flow rating matches connection size; skip to “C. Selecting Elements”.

B. When the connection size is unknown, flexible, or the required flow rating exceeds assembly flow rating:

1. match required flow rating with the element flow rating.
2. choose related connection size.

C. Selecting Elements: The filter performance is influenced by the actual application duty and the equipment it is installed on. Regular maintenance checks and proper servicing is required.

Application Duty Descriptions:

Industrial Duty: clean workshop or clean outdoor environment - small element sizing is sufficient.

Severe Duty: dirty workshop, wastewater – medium to large element is recommended.

Extreme Duty: cement, steel making, plastics or dusty material conveying – largest element sizing is recommended.

1. Select media required by your application. Options include:

a. Standard media

1. Polyester: all purpose; withstands pulses, moisture, and oily air
2. Paper: mostly dry, smooth flow applications

b. Special Media: for a variety of micron levels and media types, see the “Filter Media Specifications” in the Replacement Element Section or contact Solberg.

2. Select element size by matching the element with the anticipated duty and upsize accordingly.

Filter Assembly Maintenance

Request the appropriate maintenance manual for more in-depth information from your Solberg representative or on our website www.solbergmfg.com.

Element Maintenance

Solberg elements should be replaced once the pressure drop reaches 15-20” H₂O above the initial pressure drop of the installation. Cleaning the element is also an option.

Solberg recommends replacing dirty elements for optimal performance. Any damage which results from by-pass or additional pressure drop created by element cleaning is the sole responsibility of the operator.

Note: The overall performance of a filter element is altered once cleaned. The initial pressure drop after subsequent cleanings will be greater than the original, clean pressure drop of the element. After each cleaning, the pressure drop will continue to increase. Under all circumstances, the initial pressure drop of the element needs to be maintained at less than 15” H₂O.

If the pressure drop exceeds 20” H₂O at start-up; it should be replaced with a new element. With many types of equipment, the maximum pressure drop allowed will be dictated by the ability of the equipment to perform to its rated capacity. Under all circumstances, the operator should avoid exceeding the manufacturer’s recommended maximum pressure drop for their specific equipment.



SOLBERG[®]

www.solbergmfg.com

All model offerings and design parameters are subject to change without prior notice.
Contact your representative or Solberg for the most current information.