

Electrical Installation and Operating Instructions

1. Safety



Before installing, check the Series Number and verify compatibility to the process media and temperature in contact with the wetted parts. Incompatible media and / or operation at temperature extremes can cause premature degradation of materials which could result in safety risk to personnel.



Verify the selected pressure range (differential pressure and working pressure) and the switch ratings are within specification for your application.

Perform all electrical adjustments with power removed.

The 1100 Series Differential Pressure Gauge utilizes a diaphragm design which isolates the high process from the low process. For over pressure conditions (High over Low and Low over High) the diaphragm is supported at the end of travel for the rated working pressure of the gauge. However, it is recommended that if large pressure spikes exist, some sort of pressure limiting device should be installed for protection.



Warning!
Remaining media may result in a risk to personnel, environment etc. Use sufficient precautionary measures when removing and transporting the product.

1.1 Intended use

The indicating / non-indicating differential pressure switches are used for monitoring differential pressures in industrial applications.

The manufacturer shall not be liable for any claims if the product is used in applications contrary to the intended use.

1.2 Personnel

Personnel installing and putting this instrumentation into service shall be suitably trained and qualified in accordance with local codes, practices and regulations.

1.3 Labeling / Marking



The following Electrical Configurations bear this mark and comply with the relevant European Directives identified on the declaration of conformity: (Switch options 3, 4 & 7 in ordering information).

NOSHOK 1100 Series Diaphragm Type Differential Pressure Gauges

Electrical Installation and Operating Instructions

2.0 General Specifications

Parameter	Limits
Working Pressure(PSI)	3000 (AL)* Non Haz-Loc 1500 (Br) Non Haz-Loc 3000 (SS)* Non Haz-Loc
Proof Pressure(PSI)	6,000 (AL, SS) 5,500 (Br)
Temperature	-40° to 200° F (Switches) -20 °F to 150 °F (Transmitter)
Differential Pressure Range (PSID)	0-20" H2O to 0 to 25 PSID
Indicator Accuracy ASME B40.100	2%
DP Over-Range	+/- Proof pressure

* NACE = 1500 PSI AL & SS

Switch Specification	
Option:	3
*Power	3 W
Max. Current	0.25 Amps
Max. Voltage VAC/VDC	125
**Setting	15 to 95
(%F.S.)	10% / 5%
Hysteresis (Max/Nom)	(F.S.)
Repeatability	1% F.S.

* Product of the switching voltage and current shall not exceed the power rating of the device.

** Except where otherwise noted

NOSHOK 1100 Series Diaphragm Type Differential Pressure Gauges

Electrical Installation and Operating Instructions

Transmitter Specifications: (Calibrated on Increasing pressure)				Comments:
Operating Temperature (Max.)	-20 °F - 150 °F			
ELECTRICAL:				
	Min	Typ	Max	
Transmitter Accuracy (FSR)			2%	Upper 80% of Full Scale Range
Supply Voltage (3) (Vdc)	8		28	Pin 3 Reverse Polarity Protected
Output Current (ma)				
Zero Floating (2)	4.0 – 20.1 ma	4.0 – 21.0	4.0 – 22.0	Pin 2
Zeroed (1 connected to 2)		8		
Voltage (Pin 2 to 1)	4.8		6.3	
Zero Time (seconds)	2			
Max Loop Resistance (ohms)			1000	
Max Loop Resistance Formula	$((V_s - 8) * 1000) / 20$			
INTERFACE:				
Electrical:				
Connections:	4 Position Terminal Strip; ½" NPT Conduit 1= Rtn, 2= Zero, 3 = 8-28 Vdc In 4= Chassis			22 Awg – 16 Awg Wire
Environmental Rating:	NEMA 4X			

NOSHOK 1100 Series Diaphragm Type Differential Pressure Gauges

Electrical Installation and Operating Instructions

3.0 Product Description

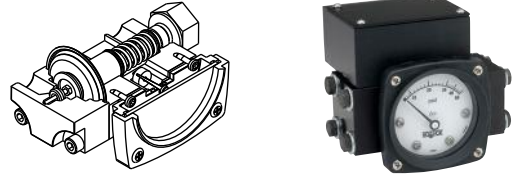

Switch

A flexible elastomer diaphragm and calibrated range spring are moved by differential pressure. A magnet, coupled with the diaphragm, transmit this motion through the wall of the pressure housing to a follower magnet attached to an indicating pointer. The rotation of the follower magnet causes the pointer to track the movement of the internal magnet and indicate the differential pressure on the dial scale. The switches are also magnetically operated and are located outside of the pressure housing. The switches are mechanically adjustable allowing the customer to set the switch within a defined adjustment span of the range of the instrument.

Transmitter

The 1100 Series indicating / non-indicating differential pressure transmitter is a 2 wire loop powered microprocessor based 4-20 ma transmitter. The magnetic angle sensor & electronics senses the angle (relative to the transmitter sensor) of the magnet which moves linearly in the bore. Each transmitter is individually calibrated to the gauge using an 11 point calibration linearization technique. This method results in a <2% full scale accuracy for the upper 80% of the range.

4.0 Installation

Mechanical Connections

¼" FNPT are provided standard, however check your paperwork to confirm the connections ordered. There are 2 connections identified on the gauge body as "Hi" and "Lo" for High pressure and Low pressure respectively. Be sure these are plumbed properly in your system. Improper connection will not damage the instrument, but it will not function properly.



Do not allow gauge fittings to rotate when making process connections. Calibration and / or pressure rating of the product may be compromised.

For end connected or gauges supplied with adapter fittings use two wrenches when making connections. Use one wrench to hold the pressure port fitting on the gauge and the other to tighten the process pipe or tube fitting.

Instrument Location

On liquid service the instrument should be mounted below the process connections to facilitate self-bleeding. On gas service it should be located above the process connections to promote self-draining. If the process contains particulates, a pigtail loop or drop leg (manometer "U-tube" configuration) in the tubing will minimize the possibility of it migrating into the instrument.

NOSHOK 1100 Series Diaphragm Type Differential Pressure Gauges

Electrical Installation and Operating Instructions

Temperature Limitations

For process temperatures higher than the rated temperature of the dp gauge / switch, use process tubing to reduce the temperature. A general “rule of thumb” is that for horizontal tubing runs the temp drop is 100° F/ ft. Another option is to use “cooling towers” to protect the instrument.

Verify the selected elastomer option is appropriate for your operating temperature.

Wall / Pipe / Panel Mounting

Not all combination of options can be wall, pipe, or panel mounted. If your unit is supplied with a wall or panel mount, possible configurations are shown below:

Wall Mount Configurations:

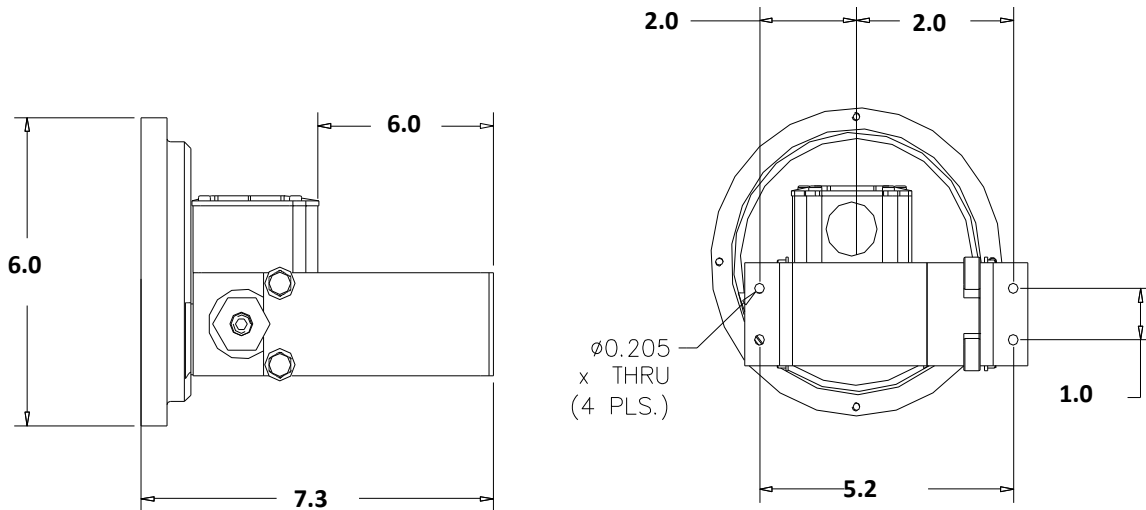

4 1/2" Dial configuration shown. Bracket is the same for the 2 1/2" Dial

Pipe mounting brackets are not available for any Electrical Configurations in the reverse port configuration.

NOSHOK 1100 Series Diaphragm Type Differential Pressure Gauges

Electrical Installation and Operating Instructions

Wall Mount Configurations (cont'd)

Typical 2nd Pipe Mounting

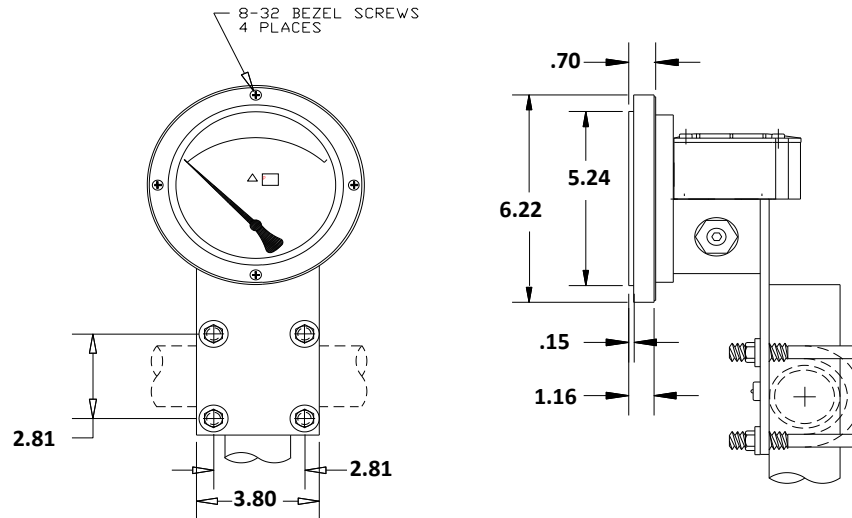

Panel Mount

Gauges with 2 ½" dials can only be mounted through the rear of the panel. Make the proper panel cutout as shown below. Remove the (4) bezel screws and insert the gauge front through the rear of the panel. Reinstall the bezel screws through the front of the panel and into the gauge bezel. Tighten screws securely in an alternating diagonal pattern.

Gauges with 4 ½" dials should be mounted from the front of the panel. Make the cutout as indicated below. Insert the (4) panel studs, finger tight, into the metal inserts located in the rear of the bezel. Insert the gauge through the panel, aligning the panel mounting studs with the holes in the panel. Install the (4) 8-32 nuts onto the studs and tighten securely.

NOSHOK 1100 Series Diaphragm Type Differential Pressure Gauges

Electrical Installation and Operating Instructions

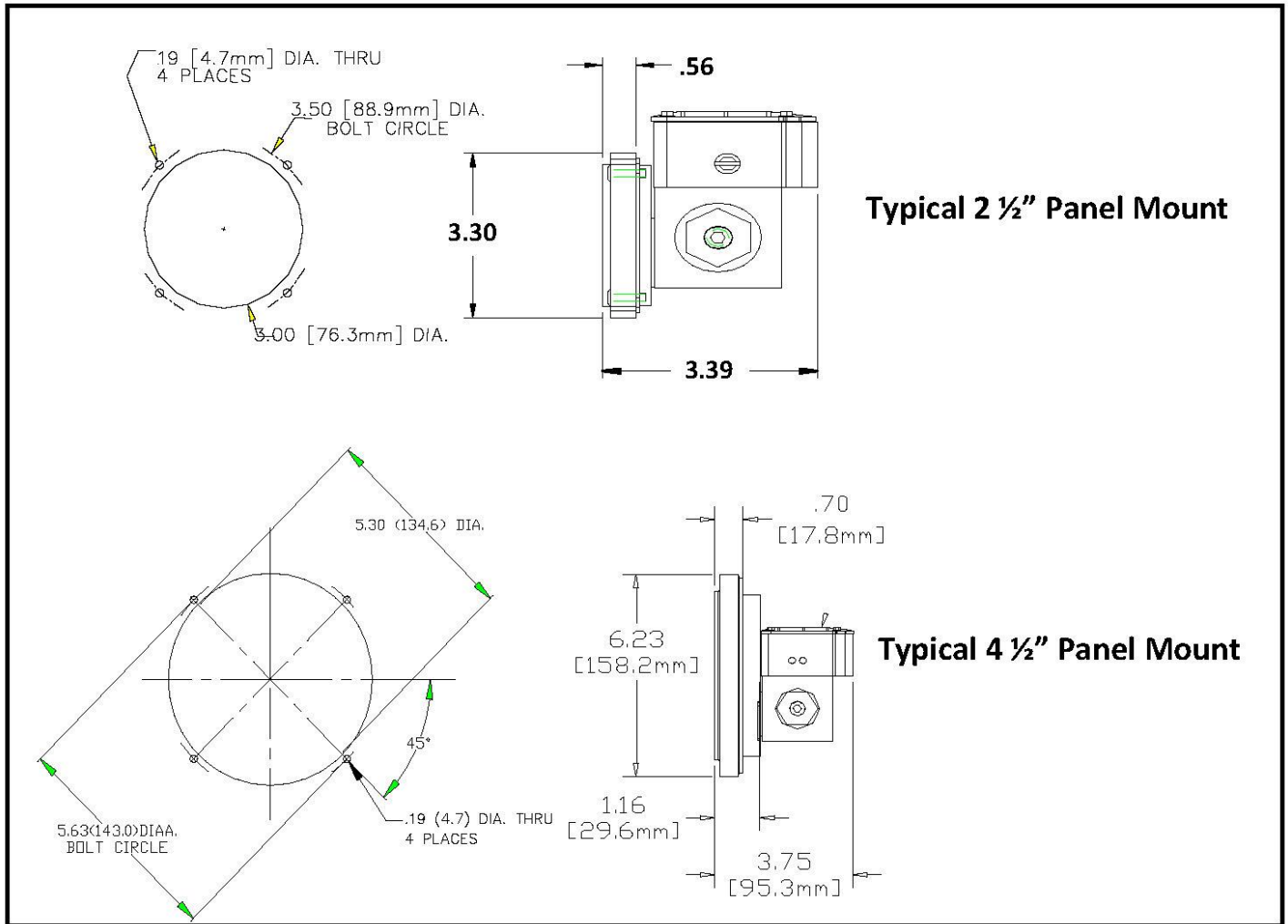

Electrical



Warning: Electrical connections should be performed by qualified personnel and meet the representative country's national electrical code.

Warning: Failure to connect to the protective conductor terminal may result in a shock hazard.

Warning: Perform all switch adjustments with power removed. Use an ohmmeter or equivalent to monitor contact operation.

Caution: Preference should be given to setting the switch prior to installation. It is also recommended to perform adjustments using a non-magnetic screwdriver.

General

All switch types are field adjustable. The defined range of the adjustment is specified in the table above. All switches come with a decal to identify adjustment direction to increase the set point.

NOSHOK 1100 Series Diaphragm Type Differential Pressure Gauges

Electrical Installation and Operating Instructions

Switch Set Point Adjustment



Caution: Do not confuse the switch adjust access as the switch adjust screw.

Note: Switches can be set below the defined minimum set point however, the switch may not remain activated at maximum PSID. If the unit is set below the defined minimum set point, the customer should verify that the switch remains activated from the set point to over range of the gauge.

The switch may be set using the indicating dial as a reference (units with a dial) or by using a reference pressure gauge.

For setting on increasing pressure increase your pressure to the desired set point. Increase the switch set point above the desired switch set (switch deactivated). Slowly decrease the switch set point until the contact activates.

Contact Protection

Provide standard protection techniques for the switch contacts for capacitive and inductive loads. Use current limiting techniques near the switch to protect the contacts due to high inrush (i.e.; in line resistor or inductor) for long cable interfaces. Provide clamping devices at or near inductive loads (i.e.; relay).



Maximum wire length between the 3W switch and its load should not exceed 70 – 100 feet for 120 VAC applications.

Connections:



Warning: When wiring to the terminal strip, make sure all wire strands are contained within the terminal connection.

The reed switch(es) are located inside the enclosure, on the top of the pressure housing (standard port), and are connected to a 7 position terminal strip. An opening is provided at the rear of the enclosure for a 1/2" flexible weather-proof cable or conduit connector (supplied by customer) (3 & 4 Electrical Configurations). Upon request the hole may be sized to accommodate a PG-11 cable gland connector.

To access the terminal strip remove the switch enclosure cover by removing the (4) screws. Insert wires through an appropriate (not supplied) weatherproof connector into the enclosure and connect to the terminal strip per the terminal strip diagram shown below or on the underside of the switch enclosure cover. The center connection is for connection of a protective conductor and is connected to the body of the pressure gauge.

The terminal strip will accept wires in the range of 22 Awg - 16 Awg.. Reinstall the cover, gasket, and (4) screws. (Fig. 3) after connection of field wiring.

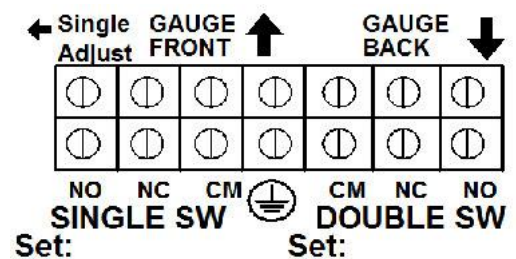

NOSHOK 1100 Series Diaphragm Type Differential Pressure Gauges

Electrical Installation and Operating Instructions

Electrical Configurations 3 & 4



Electrical configurations 3 & 4 can be used in Pollution degree 3 Industrial type areas. These configurations are rated NEMA 4X IP 65.



The enclosure for Configurations 3 & 4 is a molded plastic, whereas the enclosure for configuration 7 is made from aluminum.

Note: Configurations 3 & 4 have an electrical access hole (.875). The safety evaluation and the NEMA ratings for these configurations was performed with this access sealed.

A reverse port gauge has the switch housing located on the bottom of the gauge body.

Electrical Configuration: (Transmitter Option 7)

Intended use:

The transmitter is intended for use in General Purpose Locations (Electrical configuration 7) and the enclosure carries a NEMA 4X IP65 environmental rating.



Description:

The transmitter assembly if CE marked is also compliant with EMC Directive 2004/108/EC. The transmitter has a factory programmed low-pass filter. The filter is set to approximately 1 second. This can be increased or decreased upon customer request at the time of order.

Note: The transmitter circuitry senses the position of a magnet. Any magnetic object located near the gauge will affect transmitter accuracy. It is highly recommended to mount this product with non-magnetic materials (SS / Aluminum). If the product is ordered with a Carbon Steel bracket, we calibrate the product with the bracket attached to the product.

The transmitter if necessary can be zeroed by jumpering pin 2 to Gnd pin 1 momentarily for 2 seconds (with the unit powered). In most cases this will never be necessary as the transmitter is programmed to generate a 4ma output for the first 4% of the FSR.



Caution: Do not zero the transmitter with pressure applied. Otherwise your product will have a negative offset equivalent to the pressure when the zero was activated.



Caution: Do not attempt to reposition the transmitter assembly within the enclosure. This voids the warranty and will “knock” the unit out of calibration. Disassembly and re-assembly of any internal process parts will also require the unit to be re-calibrated. Calibration must be performed at the factory.

NOSHOK 1100 Series Diaphragm Type Differential Pressure Gauges

Electrical Installation and Operating Instructions

Connections:

The weather-proof enclosure comes standard with a ½" FNPT conduit interface. The internal 4 position terminal strip accepts wire sizes 22 AWG – 16 AWG.

To access the 4 position terminal strip, remove the 4 cover screws from the enclosure. Connect loop power between the connections labeled 8-28 Vdc and Return (see Figure below). Connect the protective conductor wire to the terminal identified with the ⚡ symbol. See the Interface schematic below. Please note that the loop power sensing device can also be located in the ground leg.

Interface Schematic

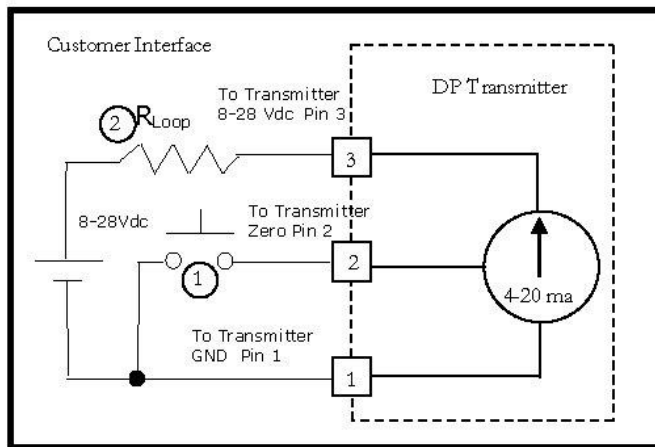

- ① Optional remote zero (customer supplied)
- ② Loop Resistor can be located in the ground leg

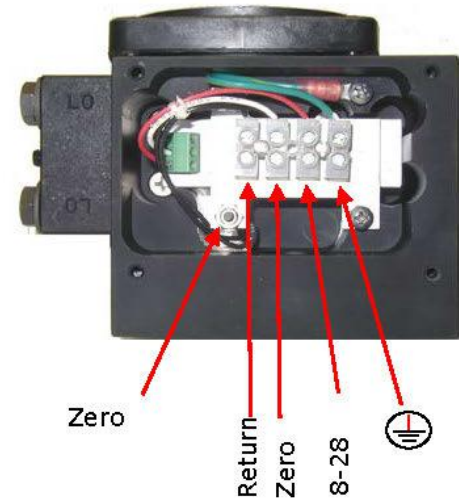

Warning: When wiring to the terminal strip, make sure all wire strands are contained within the terminal connection.

The maximum loop resistance is 1000 ohms (@ 28Vdc Input). Use the following formula to determine the maximum loop resistance at other input voltages: $((V_s - 8) * 1000) / 20$

NOSHOK 1100 Series Diaphragm Type Differential Pressure Gauges

Electrical Installation and Operating Instructions

ELECTRICAL CONFIG: 3 & 4

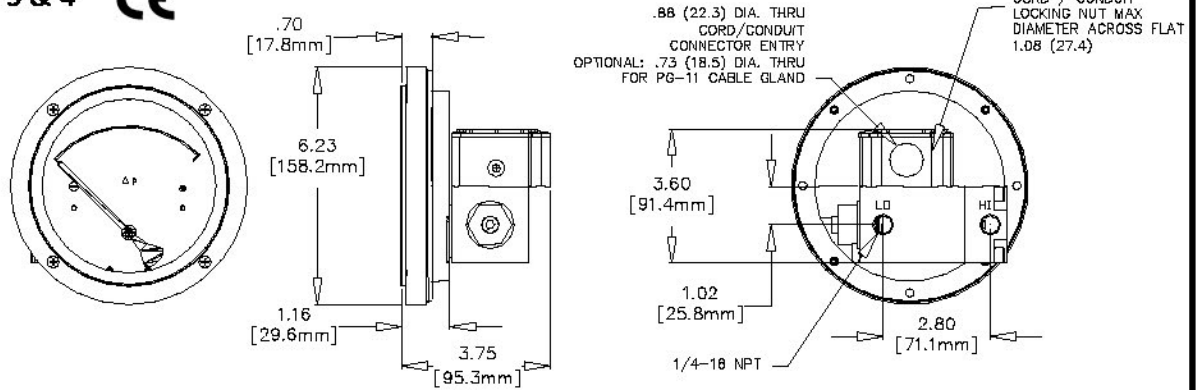

ELECTRICAL CONFIG: 3 & 4

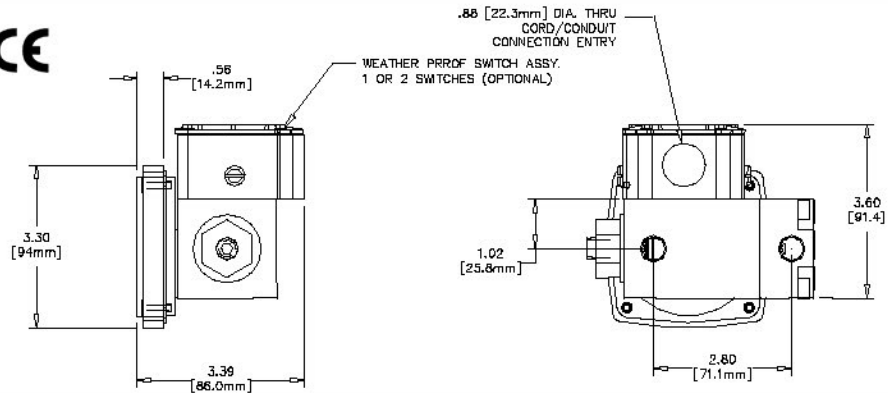

ELECTRICAL CONFIG: 7

TRANSMITTER 4 1/2" & 2 1/2" DIAL

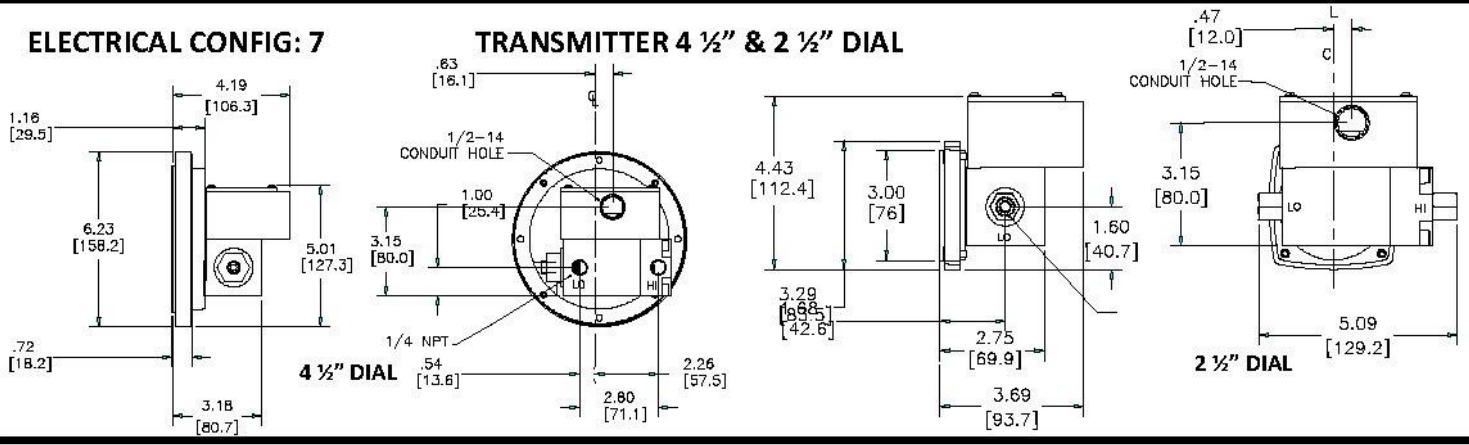

6.0 Troubleshooting

A. Gauge accuracy and set point problems:

- i. Verify your process connections are plumbed properly
- ii. Verify gauge is not in an electromagnetic / magnetic environment. i.e.; close proximity to high current power lines.
- iii. Verify the pointer has fluid movement as pressure increases. No movement may indicate a blown diaphragm.
- iv. All others contact the factory for assistance.

B. Switch doesn't function

- i. Make sure that the switch load does not exceed the specified wattage rating of the switch. (steady-state and transient). Contact factory for assistance for excessive loads, otherwise proceed to the next step.
- ii. Perform a continuity check of the switch contacts by trying to actuate the switch using an external magnet. An operational switch usually indicates a problem with the gauge. If not operational proceed to the next step.
- iii. Verify the reed switch wires are connected to the terminal strip (NEMA 4X enclosure only). Contact the factory for assistance if the switch is connected and/or request an "RGA" number.

C. Transmitter doesn't function

- i. Make sure you have supplied power (proper voltage) to the unit.
- ii. Check that you are wiring to the correct Interface terminals.
- iii. Check the transmitter interfaces to the terminal board for loose connections.
- iv. Make sure that the loop resistance does not exceed the specified rating.
- v. Make sure you did not zero the unit with pressure applied. Try a re-zero at 0 pressure.